

FRONT ELEVATION

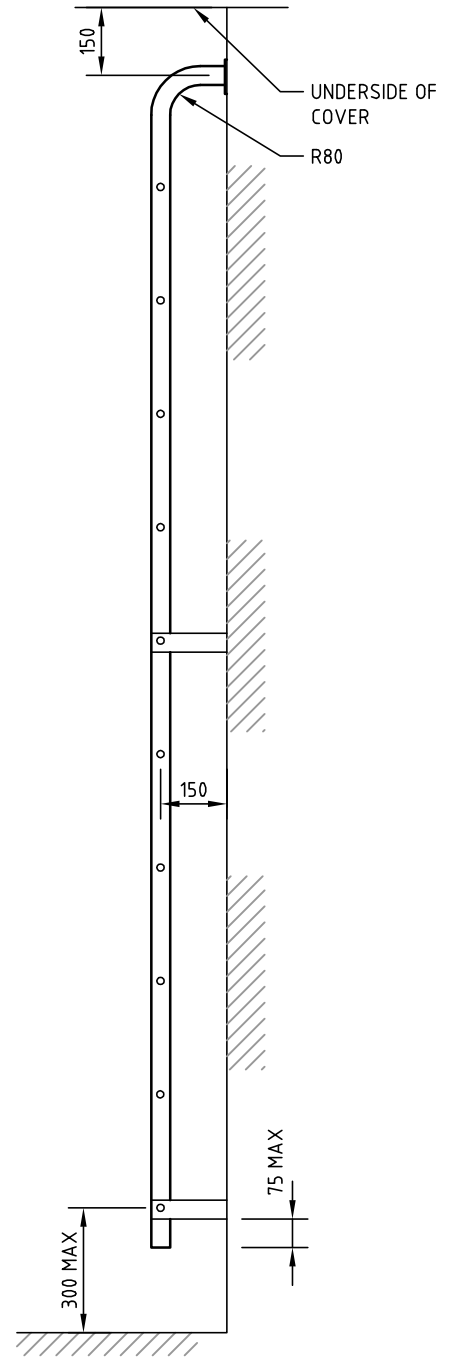

SIDE ELEVATION

NOTE ALL BOLTS TO BE M12 OR M12 CHEMICAL ANCHORS TO CONCRETE

NOTES:

1. LADDERS SHALL BE FITTED IN PITS DEEPER THAN 2400 MILLIMETRES
2. MATERIAL FOR LADDERS SHALL BE STRUCTURAL GRADE 250 TO AS1204.
3. ALL WELDING SHALL CONFORM TO AS 1554 PART 1.
4. ALL STRUCTURAL STEEL SHALL BE HOT-DIP GALVANISED AFTER FABRICATION AS SPECIFIED IN AS 1650.
5. ALL SHARP EDGES SHALL BE ROUNDED BEFORE GALVANIZING.
6. ALL OTHER STEEL COMPONENTS - NUTS, BOLTS, WASHERS, ETC. SHALL BE GALVANIZED.
7. LADDERS SHALL BE FREE FROM DEFECTS LIABLE TO CAUSE DAMAGE TO THE HANDS.

NOT TO SCALE

ENGINEERING SERVICES BRANCH



CITY OF MELBOURNE

**STANDARD MCC
RUNG LADDER DETAIL**

Approved By

Principal Engineer
Infrastructure

Date Nov, 2010

Manager
Engineering Services

Date Nov, 2010

Drawing
Number

1P 50322

Revision

E

Docs
Number