

FUTURE STREETS FRAMEWORK 2030 AND BEYOND

DRAFT

TO GUIDE THE DESIGN AND
DELIVERY OF STREETS IN THE
HODDLE GRID



CITY OF MELBOURNE



Acknowledgement of Traditional Owners

The City of Melbourne respectfully acknowledges the Traditional Owners of the land, the Wurundjeri Woi-wurrung and Bunurong Boon Wurrung peoples of the Eastern Kulin and pays respect to their Elders past, present and emerging. We are committed to our reconciliation journey, because at its heart, reconciliation is about strengthening relationships between Aboriginal and non-Aboriginal peoples, for the benefit of all Victorians.

Council Plan 2021-25

The Council Plan 2021-25 sets out our strategic direction and commitment to the community for the next four years. Based on six strategic objectives for our city, this is our detailed plan for our city's revitalisation and considers the needs of all people who access and experience the City of Melbourne municipality. For more information visit melbourne.vic.gov.au/council-plan



Safety and wellbeing

Ensuring the city is safe, and that people feel safe when they come into the city is our priority. We will plan and design for the safety and health and wellbeing of all people in Melbourne, and we are committed to strengthening community social connections.

CONTENTS

Introduction	6	Part 1 - Street types	30
Strategic context	8	Overview	31
Key influences for designing future streets	14	Principles for all streets	34
Streets for an Aboriginal City	15	Melbourne Square	36
Streets for a safe, accessible and equitable city	18	City Street with trams	38
Streets for a thriving economy and unique experiences	20	City Street with buses	40
Streets for a resilient water catchment	24	City Street with bikes	42
Streets for a cool, green and diverse ecosystem	26	Little Street	44
Streets for an intuitive and ever-changing city	28	Laneway	46
		Part 2 - Place character	48
		Overview	49
		South East	50
		Central	52
		North	54
		North East	56
		South West	58
		North West	60
		Next steps	63

Issue 01 - Draft Future Streets Framework

June 2023

Disclaimer

This report is provided for information and it does not purport to be complete. While care has been taken to ensure the content in the report is accurate, we cannot guarantee it is without flaw of any kind. There may be errors and omissions or it may not be wholly appropriate for your particular purposes. In addition, the publication is a snapshot in time based on historic information which is liable to change. The City of Melbourne accepts no responsibility and disclaims all liability for any error, loss or other consequence which may arise from you relying on any information contained in this report.

To find out how you can participate in the decision-making process for City of Melbourne's current and future initiatives, visit participate.melbourne.vic.gov.au

INTRODUCTION

The Future Streets Framework (the framework) guides the design and delivery of streets in Melbourne’s Hoddle Grid, on Wurundjeri Woi-wurrung Country.

The Hoddle Grid is widely recognised as the heart of Melbourne. It has always been a place of gathering, socialising, ceremony and storytelling, of ongoing knowledge sharing and spiritual practice. Despite the impact of colonisation, connection to Country is ever-present and there are opportunities to improve this.

Our streets are the most extensive and significant public spaces of inner Melbourne and have great influence on the perception of the city (Grids and Greenery, City of Melbourne, 1987). Melbourne’s bluestone footpaths, street furniture, trees, outdoor dining, tram routes and bike lanes all contribute to the high quality experience and unique character of Melbourne. While streets perform many functions, it is important that a careful balance is achieved to ensure the safety, function and amenity of the city for all users.

Additionally, Victoria’s economic prosperity is reliant on a productive central city. The central city is the centre of the state’s transport network and contains the largest concentration of Victoria’s key economic, social and cultural assets. Given it has the greatest demand for travel, supporting residents, workers, business owners and visitors through walking, cycling and public transport is crucial to the city’s ongoing economic success.

The framework implements Action 1 of the Transport Strategy 2030:

“[...] to develop a Future Streets Framework to design and deliver streets in the Hoddle Grid based on the 2030 Proposed Integrated Network [...]”.

The Transport Strategy 2030 was endorsed by City of Melbourne in October 2019. The 2030 Proposed Integrated Network in the strategy sets out the transport priorities across the municipality including public transport, bike lanes, pedestrian movement and vehicles.

The framework seeks to achieve consensus on the preferred design of streets, implementing the strategic directions of the Transport Strategy 2030 with other City of Melbourne strategies, plans and standards relating to streets. The framework also acknowledges the Department of Transport and Planning’s (DTP) Movement and Place Framework, recognising that streets perform multiple functions and have different priorities.

Streets are for everyone. The framework seeks to **create a balance and provide more choices for people to access the city.**

The study area

The Future Streets Framework covers the streets known as the Hoddle Grid, bound by Flinders Street in the south, Spring Street in the east, Spencer Street in the west and Victoria Street in the north. The framework also includes streets to the south of Victoria Street, such as Franklin, Peel and A’Beckett Streets, forming part of the broader central city. For the purpose of this report, the entire study area will be referred to as the Hoddle Grid.

Objectives of the framework

The purpose of the Future Streets Framework is to establish a long-term vision for the design and delivery of streets in the Hoddle Grid. There are five key objectives of the framework:

- To reinforce and consolidate endorsed strategies, guidelines and plans with innovative approaches to street design that respond to the existing and emerging needs of Melbourne.
- To give clarity about the type of change that can occur in streets in the Hoddle Grid, aligned with the implementation of the Transport Strategy 2030.
- To support the economic growth of the city through the strategic investment in street upgrades, recognising the importance of streets in contributing to a vibrant, high quality, green and sustainable city.
- To identify and prioritise projects to be delivered through the Capital Works Program or advocated through stakeholder-led projects and partnerships.
- To achieve consensus between City of Melbourne, community, developers and stakeholders on the design of streets to enable projects to be delivered more efficiently.

Purpose of the framework

The framework enables the coordinated design and delivery of street upgrades in the Hoddle Grid. It provides an essential tool for the evaluation, planning and design of projects to 2030 and beyond.

The framework enables engagement with the Victorian Government and key stakeholders on the preferred design of streets, integrate upgrades with major infrastructure projects and identify funding opportunities for the delivery of public realm improvements.

The framework is to be used in conjunction with all applicable standards and technical documentation.

The framework is not intended to propose detailed designs for individual streets. Future design phases will comprise existing conditions analysis, technical studies, and traffic impact assessments to ensure the design of a street meets local needs. Future design phases on street projects will also include community and stakeholder consultation.

Structure of the framework

The Future Streets Framework considers both system-wide influences and local approaches to guide best practice street design. This recognises that streets are a part of broader transport, environment, social and economic considerations.

System-wide considerations:

- **Key influences for designing Future Streets** are the overarching environmental, economic, social and cultural layers that inspire meaningful street design.

Local considerations:

- **Part 1 - Street types** translates the strategic requirements determined by the Transport Strategy 2030 to key street types. The prevailing street types each have principles, modal priorities and preferred functional arrangements to support consistency and standardisation.
- **Part 2 - Place character** celebrates the diversity of places within the Hoddle Grid through geographically derived regions of shared character.

Figure 2: Document structure

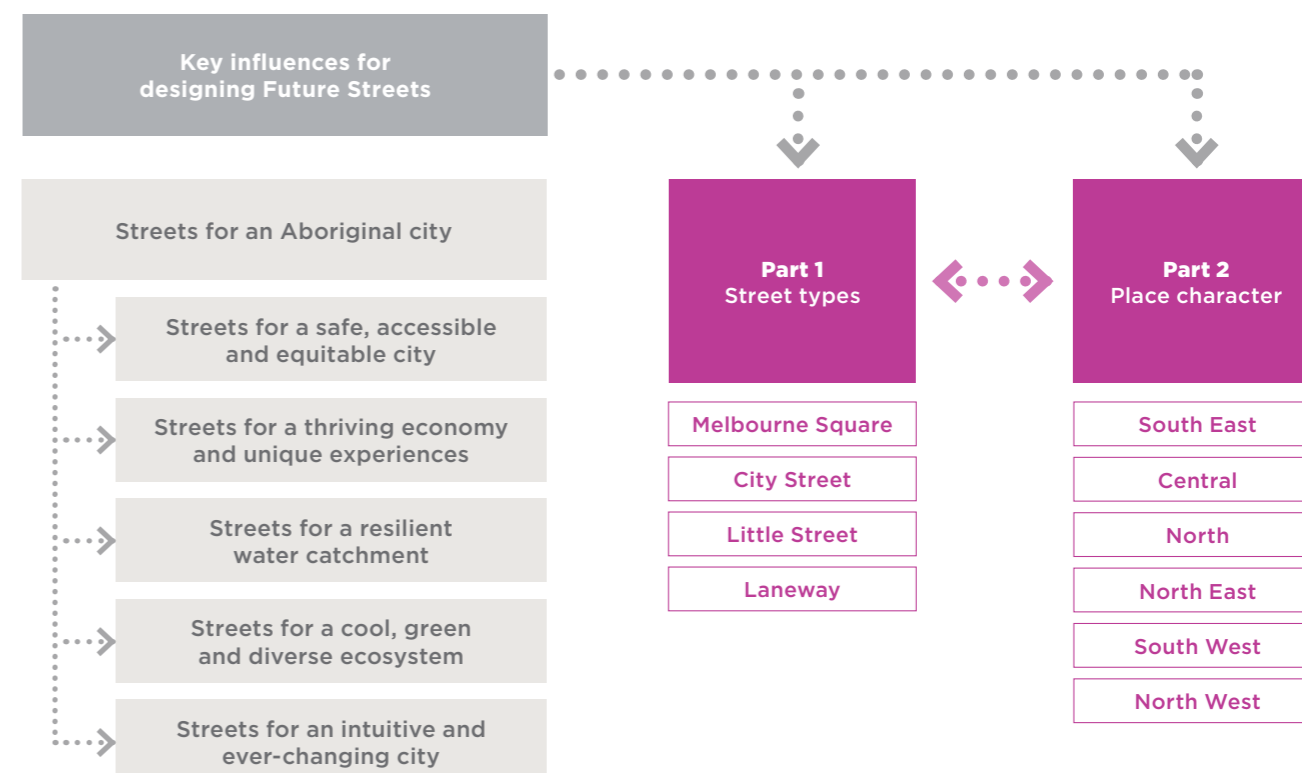

STRATEGIC CONTEXT

The City of Melbourne has a range of endorsed strategies, policies, plans and standards which set out the direction for streets within the Hoddle Grid. These documents assist city shapers and decision-makers to deliver vibrant and enduring streets that meet the diverse needs of the city.

The Future Streets Framework synthesises these references to provide a holistic vision and design principles for streets within the Hoddle Grid.

The following figure positions the framework:

Figure 3: Strategic position of the Future Streets Framework

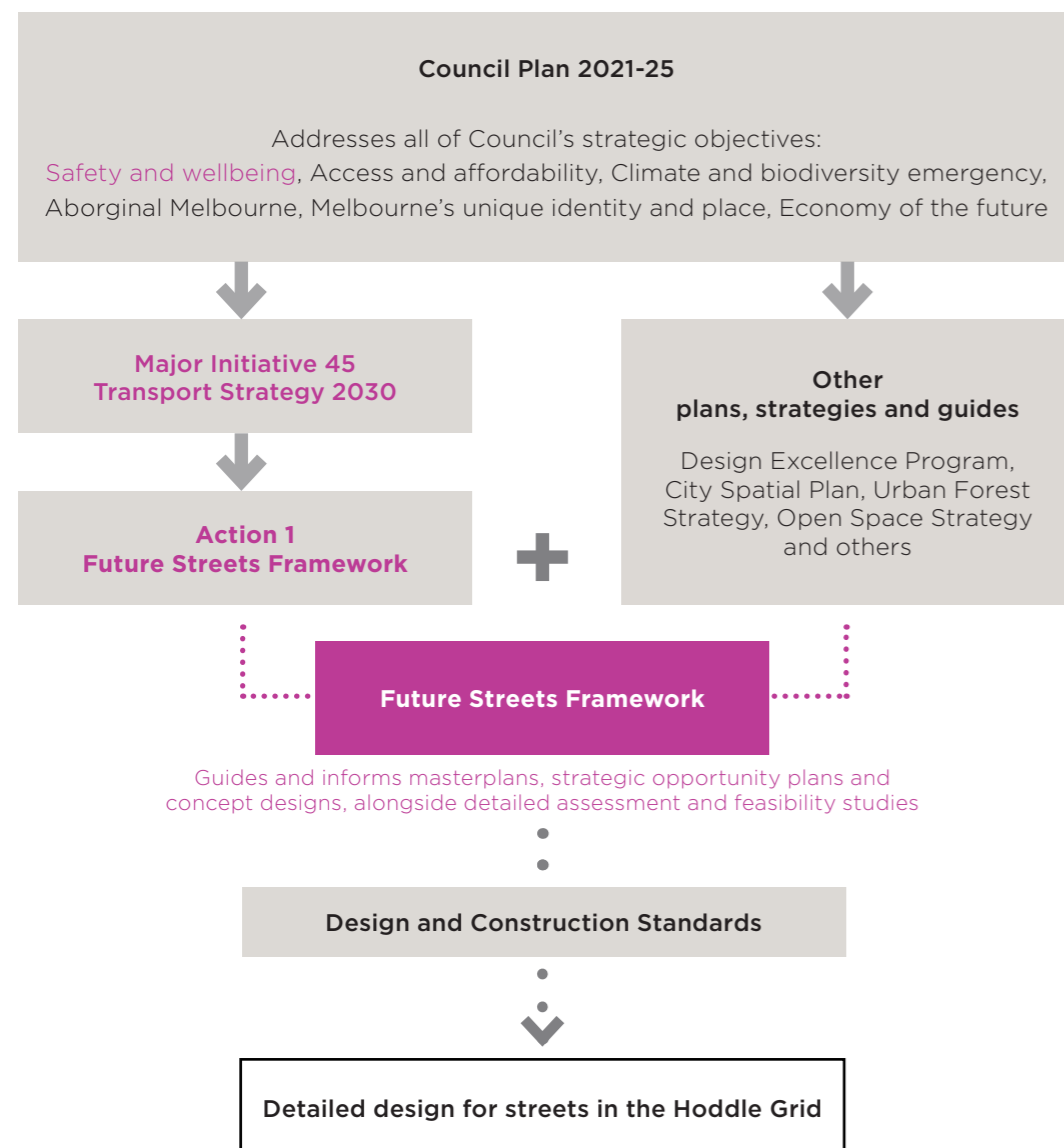

Council Plan 2021-25

This framework directly responds to the following initiatives within the Council Plan 2021-25:

Safety and wellbeing major initiative:

Continue to implement the Transport Strategy 2030, including delivery of a protected bike lane network, station precincts as key gateways, little streets as streets for people, safer speed limits, micro mobility trials, more efficient traffic signal timing, developing an approach to support electric vehicles, and bicycling encouragement programs.

Additionally, streets play a key role in achieving the strategic objectives in the Council Plan 2021-25. The 10 year community aspirations outlined in the plan specifically call out streets and/or opportunities for streets:

- Aboriginal Melbourne**
Explore and deliver opportunities for 'truth-telling' to facilitate learning, healing, and change within Melbourne and beyond. This will be an opportunity to impart knowledge of thousands of years of rich history, language and stories, as well as provide a form of restorative justice by acknowledging Aboriginal peoples' experiences of dispossession and inequity.
- Economy of the future**
The creative energy of the municipality is harnessed and enhanced to be a defining feature of Melbourne's unique character and contributes to its ongoing economic resilience and viability.
- Melbourne's unique identity and place**
Melbourne's unique streetscapes, open and green spaces, built environment and neighbourhood character are protected and enhanced as the city grows and evolves.
- Climate and biodiversity emergency**
The city continues to strengthen its dense network of green streets and spaces so that plants and animals can thrive and communities can come together.

As a major capital city, it is critical that Council Plan initiatives are underpinned by holistic and sustainable approaches. The Sustainable Development Goals (SDGs) are an ambitious set of 17 goals that United Nations member states have committed to achieve by 2030. Each of these goals have associated targets and unique indicators.

City of Melbourne has sought to localise the SDGs as a means to track progress, make informed decisions, benchmark performance and share success. The City of Melbourne Voluntary Local Review 2022 (the review) uses data and insights to monitor performance annually.

The review identifies meaningful ways that streets can contribute to addressing the goals, aligning with the Transport Strategy 2030 and other strategies and plans. The most relevant goals to the Future Streets Framework include:

- Reduce by half the number of people killed or seriously injured on our streets.
- Reduce by half the proportion of central city through-traffic.
- Increase public transport, walking and cycling mode share to 70 per cent of all trips.
- Increase proportion of women cycling to 40 per cent.
- Design in ways that minimises impact on the water cycle through Water Sensitive Urban Design and capturing and treating stormwater.
- Double our canopy cover over the next 20 years, increase vegetation diversity and improve vegetation health, soil moisture water quality and urban ecology.



Transport Strategy 2030

The Transport Strategy 2030 establishes a long-term vision to provide more space for pedestrians, people on bikes and users of public transport. The Transport Strategy 2030 seeks to provide more space for people on footpaths and around major transport hubs, boost Melbourne's \$5.7 billion retail and hospitality sector, and deliver \$870 million in economic benefits to Victoria over the next decade.

The 2030 Proposed Integrated Network in the Transport Strategy 2030 identifies the transport priorities across Melbourne's street network. Figure 4 illustrates these directions within the Hoddle Grid.

As set out in Action 1 of the strategy, the Future Streets Framework for the Hoddle Grid provides guidance on the functional arrangement of street space to safely accommodate the required transport modes, while providing space for complementary streetscape elements and functions such as trees, landscape, water sensitive urban design, furniture, activities all of which contribute to a high quality public realm for a vibrant city.

Key outcomes of the Transport Strategy 2030

Outcome 1: Safe streets for people

- 1.1 Redesign streets in the Hoddle Grid
- 1.2 Reallocate more space to people walking in the city
- This includes key improvements to streets by:
 - Narrowing traffic lanes and introducing traffic calming
 - Removing kerbs where possible to create level streets
 - Reallocating on-street parking to people space
 - Converting some streets into pedestrian-priority zones
 - Working towards a maximum of one traffic lane each way on all streets in the Hoddle Grid, except King Street
- 1.3 Design safe and accessible streets for everyone
- 1.4 Adopt a strategic approach to managing footpath obstructions
- 1.6 Proactively facilitate a permeable street network
- 1.7 Deliver physically protected environments for people through innovative urban design

Outcome 2: Safe streets for bike riding

- 2.1 Deliver our proposed network of protected bicycle lanes into and through the central city
- 2.2 Make every street safer for cycling

Outcome 3: Transport interchanges as welcoming people-places

- 3.1 Transform precincts around major transport interchanges into welcoming places for people
- 3.2 Design tram stops which are seamlessly integrated into streets
- 3.3 Support new clean and green bus streets

Outcome 4: Fewer non-essential vehicles in the municipality

- 4.1 Reduce central city through-traffic
- 4.3 Ensure access for people with disabilities as well as essential vehicles *

Outcome 7: Use kerb space more efficiently

- 7.1 Proactively manage kerb space to boost efficiency and productivity **

*Note: Associated "Policy 13: Ensure street and loading access is facilitated when off-street space is unavailable, for freight, tradespeople, servicing and construction."

** Note: The demand for car parking may reduce in the future, as travel by sustainable modes becomes easier, as people shift to different types of car travel (such as car share and rideshare) and as new technology arrives. This project seeks to align with the Parking and Kerbside Management Plan (Action 20 of the Transport Strategy 2030).

Figure 4: The 2030 Proposed Integrated Network for the Hoddle Grid based on the Transport Strategy 2030

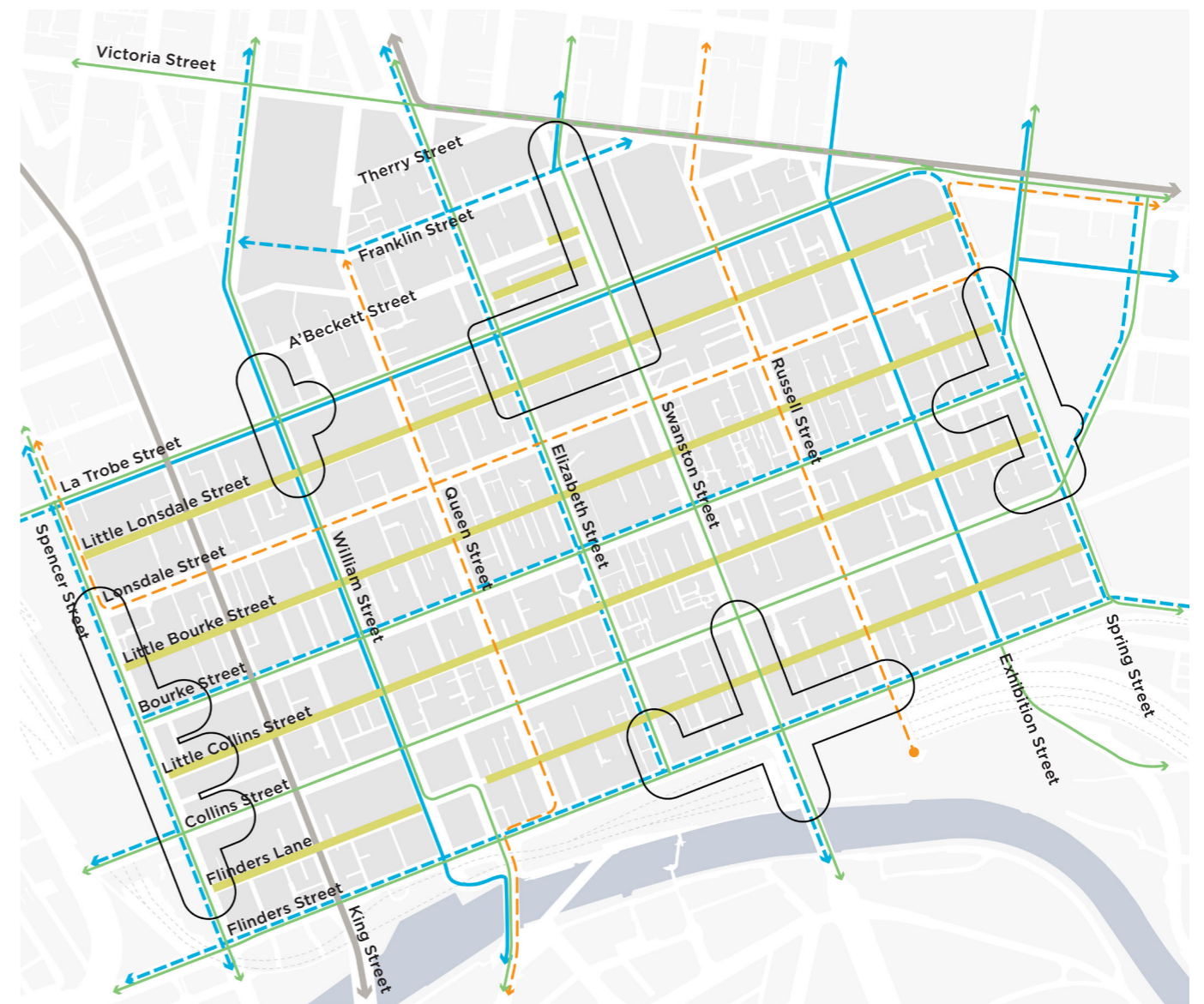

Key

- Proposed/future pedestrian priority zone
- Existing protected cycle routes
- Proposed protected cycle routes
- Proposed full-time bus priority
- Existing tram
- Proposed tram
- Primary traffic through route
- Station hub



Image 5: Bourke Street Mall

Draft City Spatial Plan

The Draft City Spatial Plan (July 2022) is the overarching strategic planning policy for the municipality. It incorporates the vision and objectives of City of Melbourne's strategies, plans, policies and responses to emerging issues for managing land use and development for the next 10 to 20 years. It considers our context, history, assets, strengths, attributes and influences, and establishes the vision and strategic direction for future land use and development.

The Draft City Spatial Plan will be a background document that underpins the Melbourne Municipal Planning Strategy (MPS). Authorisation is currently being sought from the Minister for Planning to prepare and exhibit an amendment to the Melbourne Planning scheme to update the MPS.

The Draft City Spatial Plan identifies strategic directions across the municipality that are relevant to the Future Streets Framework. For the Hoddle Grid, the following challenges and opportunities are identified in the plan:

- *Streets are not optimised for the way they are used today, with the majority of space allocated to the private vehicle and pedestrians overcrowding on footpaths.*
- *Pressure on street space and open space from large numbers of residents, workers and other city users.*
- *Prioritisation of active forms of movement, including the new and growing network of protected bike lanes.*
- *Increasing street tree planting and providing green infrastructure to cool the city's streets.*
- *New Melbourne Metro train stations.*

Design Excellence Program

The Design Excellence Program 2019-30 (the program) is aligned with Council Plan Strategic Objective 'Melbourne's unique identity and place' and forms part of major initiative 22.

'Design excellence' is a demonstrated exceptional standard of urban design, architecture and landscape architecture across buildings, streets and open spaces.

To maintain Melbourne's status as a globally leading design city and uphold its reputation as one of the world's most liveable cities, the pursuit of design excellence in both public and private realms is crucial. Design excellence is embedded across processes and projects, and demonstrates a commitment to ensuring outstanding design quality, character, function and an enduring legacy for all who live, work and visit Melbourne.

The Future Streets Framework is underpinned by the values and ambitions of the program. In a similar way that private development must contribute positively to public life, high quality streets can enhance liveability, attract and retain talent, support creative industries and build city brand and identity.



Image 6: Princess Theatre Forecourt

KEY INFLUENCES FOR DESIGNING FUTURE STREETS

There are a range of influences that guide street design. The following influences bring together considerations across City of Melbourne’s endorsed plans, strategies and emerging opportunities to ensure streets are holistically considered.

The value of streets

Melbourne is one of the most liveable cities in the world. A contributing factor is the quality of our grand boulevards, major streets, little streets and intricate laneway network. These spaces are functional, delightful and enduring.

In addition to efficiently moving people and goods, Melbourne’s streets are largely responsible for:

- sustaining civic life and participation
- nurturing character, community, biodiversity and the environment
- attracting and retaining residents and workers
- enhancing day and night-time activation
- boosting economic performance
- supporting and celebrating key destinations
- providing canopy cover in the public realm to improve the function, resilience and amenity of the city.

The Hoddle Grid over time

The urban structure and street hierarchy has greatly contributed to Melbourne’s evolving character. The contrast between the uniformity of main streets and the eccentricity of laneways is recognised globally as distinctly Melbourne. The absence of plazas, squares and parks in the original plans for the Hoddle Grid reinforces the role that streets must play in supporting public life, livelihoods and the environment as the city develops and grows.

Meeting evolving needs

Streets are valuable civic assets. They need to be versatile, functional and future-ready, and deliver multiple benefits for the city.

The CBD Neighbourhood Portal highlights neighbourhood priorities for the Hoddle Grid. These priorities reinforce the need for streets to be considered holistically including the physical and ‘invisible’ factors that interplay. Finite street space is required to perform a wide variety of functions and roles, and needs to be carefully considered in the context of population growth and meeting evolving needs.

Key priorities include:

- affordable and inclusive spaces
- accessible and easy to navigate spaces for people of all ages, abilities and backgrounds
- decarbonising transport and keeping cars out of small streets and lanes
- greening the city streets, buildings and rooftops
- enhancing resilience of the CBD through defining and promoting distinct neighbourhoods within the city
- supporting shopfront activation and night-time economy
- reactivating the city and reinventing it through innovation, creative production and new uses of city buildings and spaces.

Key influences

The following key influences have been identified for streets. They will be explored in the following pages with many influences overlapping and intersecting. Streets for an Aboriginal City is positioned as the overarching influence.



STREETS FOR AN ABORIGINAL CITY

The Hoddle Grid has always been a site for social and ceremonial practices imbued with spiritual meaning for the Kulin Nation. As we consider our future streets, we need to interrogate the processes and outcomes that meaningfully forefront designing with Country.

Key directions

- Work in partnership with Traditional Owners and the Aboriginal community to share cultural values, to reflect custodianship of the land and to welcome and involve the Aboriginal community within the city.
- Increase visibility and understanding of Woi-wurrung language and culture across the city.
- Recognise Wurundjeri Woi-wurrung people’s ongoing cultural connection to Country through signage, wayfaring, storytelling, truth-telling, placemaking and creative art initiatives.
- Adopt a holistic systems approach to street design and prioritise interdisciplinary arrangements and co-authorship processes.
- Protect and enhance the Yarra River - Birrarung through water sensitive street design to mitigate pollutants and contribute to a healthier system.
- Adopt innovative solutions to regenerate the soil and ecosystems through adaptive and sustainable street interventions.

Strategic context

A journey towards deeper understanding of Country encompasses all other considerations for street design. As we consider the future of our streets in the context of a colonial and gridded city, we require genuine engagement with, and nuanced understanding of, the multiple and complex interpretations of place and Country.

“In the Indigenous worldview, Country means a way of seeing the world. There is no separation between people and nature. It is multi-dimensional and extends beyond ‘the ground’. There is sea, land and sky Country.”

– Design: Building on Country, Alison Page and Paul Memmott

Key documents

Key Council documents / resources:

- Innovate Reconciliation Action Plan 2021-23
- Mapping Aboriginal Melbourne
- Hoddle Grid Heritage Review (July 2020)
- Inclusive Melbourne Strategy 2022-32
- Creative Strategy 2018-28

Other key documents:

- AILA Post Festival 2022 Tracking Report
- Publicly accessible Cultural Heritage Management Plans (CHMP)
- Yarra Strategic Plan 2022-32
- Wurundjeri Woi-wurrung Birrarung Water Policy

The imposition of the Hoddle Grid

In 1837, the Hoddle Grid was imposed on land to the north of the Yarra River – Birrarung. This simultaneously marginalised, diminished and forcibly displaced the Wurundjeri Woi-wurrung and their neighbours the Bunurong Boon Wurrung peoples of the Eastern Kulin who thrived for over 60,000 years before European contact.

The pre-settlement landscape was a thriving natural and cultural system; abundant, constantly adapting and diverse. The vegetation, shape of the river, topography and water flow have all dramatically changed:

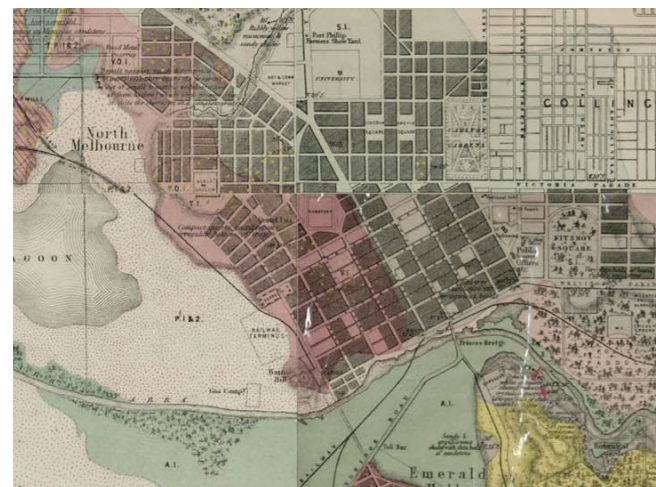

Image 7: Geological Survey of Victoria, 1858 (Source: Department of Energy, Environment and Climate Action)

The site for the Hoddle Grid presented a number of ideal conditions concerning food, resources and commerce, fertile soil, rich pastures and wooded hills, in addition to convenient access to wetlands and the river.

The topography, views, soil, vegetation, natural resources and relationship to the river all contributed to the settlers' rationale for the location and orientation of the Hoddle Grid. The early years of colonial settlement was marked by patterns of environmental destruction and exploitation, and the severance of intrinsically linked cultural practices.

The natural low point and drainage line into the Yarra River – Birrarung was piped underground and became what we now know as Elizabeth Street. Indigenous plants were rapidly replaced with European exotic species and low riverbanks became roadways. Valued natural features were also destroyed. This included the removal of a prominent hill, south of where Southern Cross Station is now located, that provided sweeping views, including towards a striking blue saltwater lagoon to the north west. The Falls, now Queens Bridge, was once a natural basalt ridge that separated fresh and salt water.

Birrarung as living entity

As an Australian and Victorian first, the Yarra River Protection (Wilip-gin Birrarung murrong) Act 2017 recognises in law the Yarra River - Birrarung as a living entity. The Yarra Strategic Plan (Burndap Birrarung burndap umarkoo) prescribed by the Act includes the Hoddle Grid within its scope given its proximity to the banks of the river. In supporting the community vision for Birrarung, street improvement and management hold important opportunities for the restoration of the Yarra River - Birrarung by mitigating pollutants from entering the river and contributing to healthy waterways.

“The Traditional Owners have always considered the Birrarung to be the lifeblood of Country. It flows across organisational boundaries, encompassing the land and waters of the river as well as its unique ecosystems. The Act and the plan return to this holistic view that recognises the Yarra and its lands as a connected entity – requiring focus, care and reverence across all reaches of the river.”

– Yarra Strategic Plan (Burndap Birrarung burndap umarkoo)

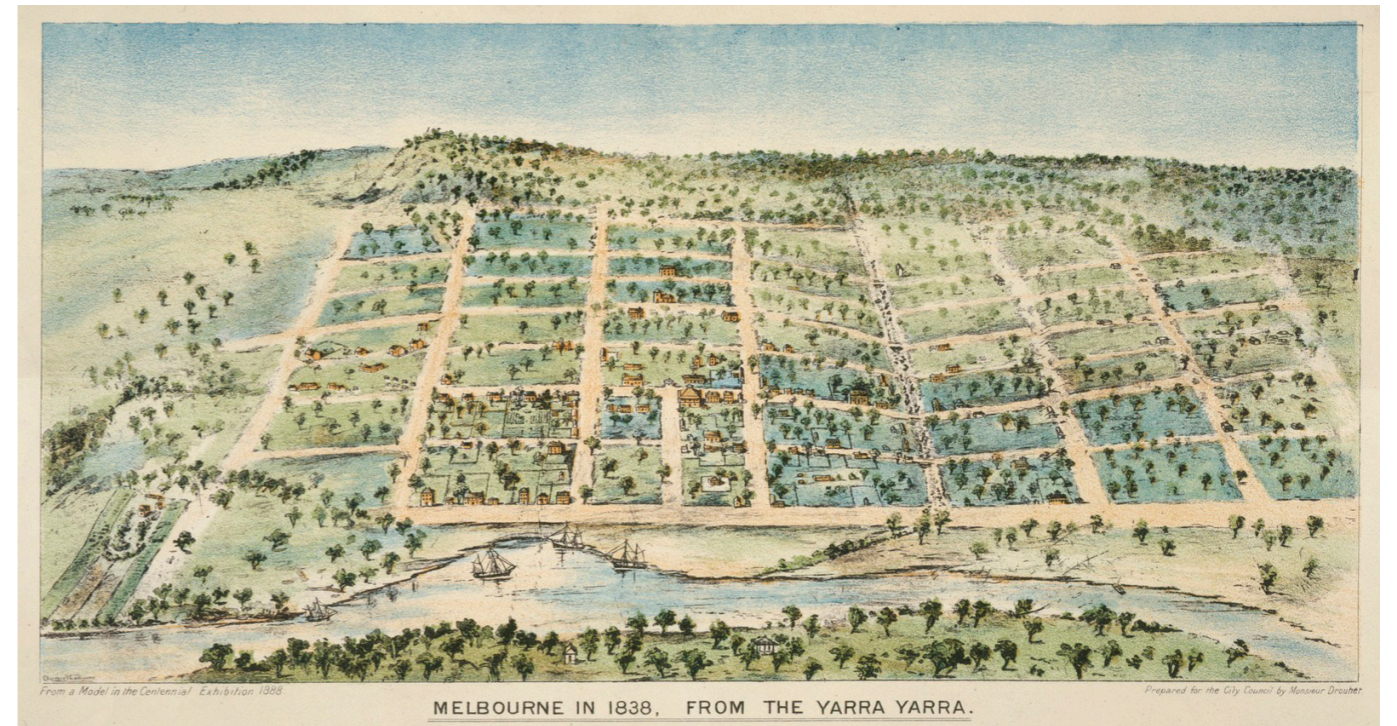

Image 8: Melbourne in 1838 (Source: State Library of Victoria)

The superimposed grid generally ignored the pre-existing topography. Streets disturbed the natural drainage systems and stagnant pools of water often formed. Significant landscape modifications and development also meant that important vantage points were lost.

Contemporary approaches

A contemporary approach to designing with Country requires a process of unlearning and dismantling preconceived ideas of city development, project design and delivery.

In the context of our gridded city, civic practitioners and designers must constantly interrogate typical practice and paradigms, recognising that design process and design outcomes are intertwined. This requires continuous learning, proactively educating all participants to city shaping and making with Traditional owners and the Aboriginal community, deep listening, meaningful collaboration and co-authorship.

As identified in City of Melbourne's Innovate Reconciliation Action Plan 2021-23 (the plan), there are many opportunities for our streets to embed values and approaches of co-authorship with Traditional Owners. As the city grows, it is our responsibility to recognise and celebrate the Traditional Owners of this land and Aboriginal community. Key actions in the plan include:

Action 12: Protect, recognise and promote Aboriginal culture, heritage and place

- 12.1 Identify and implement opportunities for the dual naming of spaces to reflect the Aboriginal cultural heritage of the area.
- 12.2 Conduct research in consultation with local Traditional Owner groups into 'Caring for Country' knowledge and practices, and how they may be applied to the work of Council in areas such as:
 - urban design
 - sustainability
 - parks and gardens
 - public art.

Action 15: Provide opportunities which support cultural, social and economic development for Aboriginal Victorians.

- 15.2 All urban and landscape designs will include appropriate design references to Aboriginal cultures in accordance with Aboriginal Indigenous Cultural and Intellectual Property rights.

STREETS FOR A SAFE, ACCESSIBLE AND EQUITABLE CITY

A safe, convenient, comfortable and accessible network of streets is essential to the ongoing function, growth and health of our city. The Transport Strategy 2030 identifies mode priorities within the Hoddle Grid to rebalance streets in response to changing travel behaviour and to maximise choice for people to access the city. This includes reallocating more space to pedestrians and bike users to support an equitable city, while also ensuring efficient movement of people and goods to support economic growth and productivity.

Key directions

- Influence major state infrastructure projects to advocate for people-oriented streetscape outcomes that alleviate pedestrian congestion.
- Continue to invest in the walking economy to enhance the success of the central city as a place to do business, visit and live.
- Increase pedestrian priority on streets surrounding major public transport hubs and major retail districts to alleviate congestion, improve safety and encourage active transport.
- Establish slow, shared environments in little streets to reinforce pedestrian priority.
- Improve sub-optimum footpath widths to support the intensity of retail and hospitality functions, while enhancing pedestrian safety.
- Continue to deliver high quality protected bike lanes in key streets that support safety of all users and encourage greater take up of cycling.
- Continue to reduce through-traffic while enabling vehicle access for local users, business owners and residents.
- Ensure physical infrastructure supports and maximises inclusive access across gender, ages, cultures, stages and abilities.
- Conduct gender impact assessments for streetscape renewal projects in accordance with the Gender Equality Act 2020.
- Address gendered differences in experience of place and apply an intersectional approach to address perceptions of safety.
- Adopt a multi-use, multi-purpose approach to streets to allow for different uses across the day and night.
- Ensure consideration for and consultation with emergency services vehicle access.
- Provide high quality urban greening and cooling features to reduce heat stress, especially for vulnerable community members.

Key documents

Key Council documents:

- Transport Strategy 2030
- Draft City Spatial Plan (July 2022)
- Gender Equality Action Plan 2022-25
- Women's Safety and Empowerment Action Plan 2021-24
- Disability Access and Inclusion Plan 2020-24
- Inclusive Melbourne Strategy 2022-32
- Health and Wellbeing Action Plan 2021-25
- United Nations Sustainable Development Goals: City of Melbourne Voluntary Local Review 2022

Other key documents:

1. Contribution of different modes of transport to city recovery (Urbis 2022)
2. Little streets pedestrian priority / shared zones review (Stantec 2023)

Strategic context

Optimising space for pedestrians and bikes

In the Hoddle Grid, 26 per cent of total street space is designated to footpaths, supporting not only pedestrian movement but also many of the essential ingredients of a high quality streetscape including trees, planting, street furniture, outdoor dining, signs, light poles, public transport infrastructure and intermittent activations.

Currently, there are many streets which experience significant pedestrian congestion and overcrowding, impacting the quality of pedestrian experiences. The highest pedestrian densities are frequently experienced around train stations and tram stops as well as popular retail and civic destinations. In such areas, a good pedestrian network is fundamental in maximising interaction between people doing business which also drives the economy. Moreover, a person walking to the central city makes the greatest contribution to the city economy¹.

Some sections of little streets, also experience high pedestrian densities on weekends and at night. The implementation of shared zones and traffic calming on little streets have generally reduced traffic volumes and speeds, however more measures to support pedestrian demand and land uses can further improve safety².

Figure 9: Existing conditions

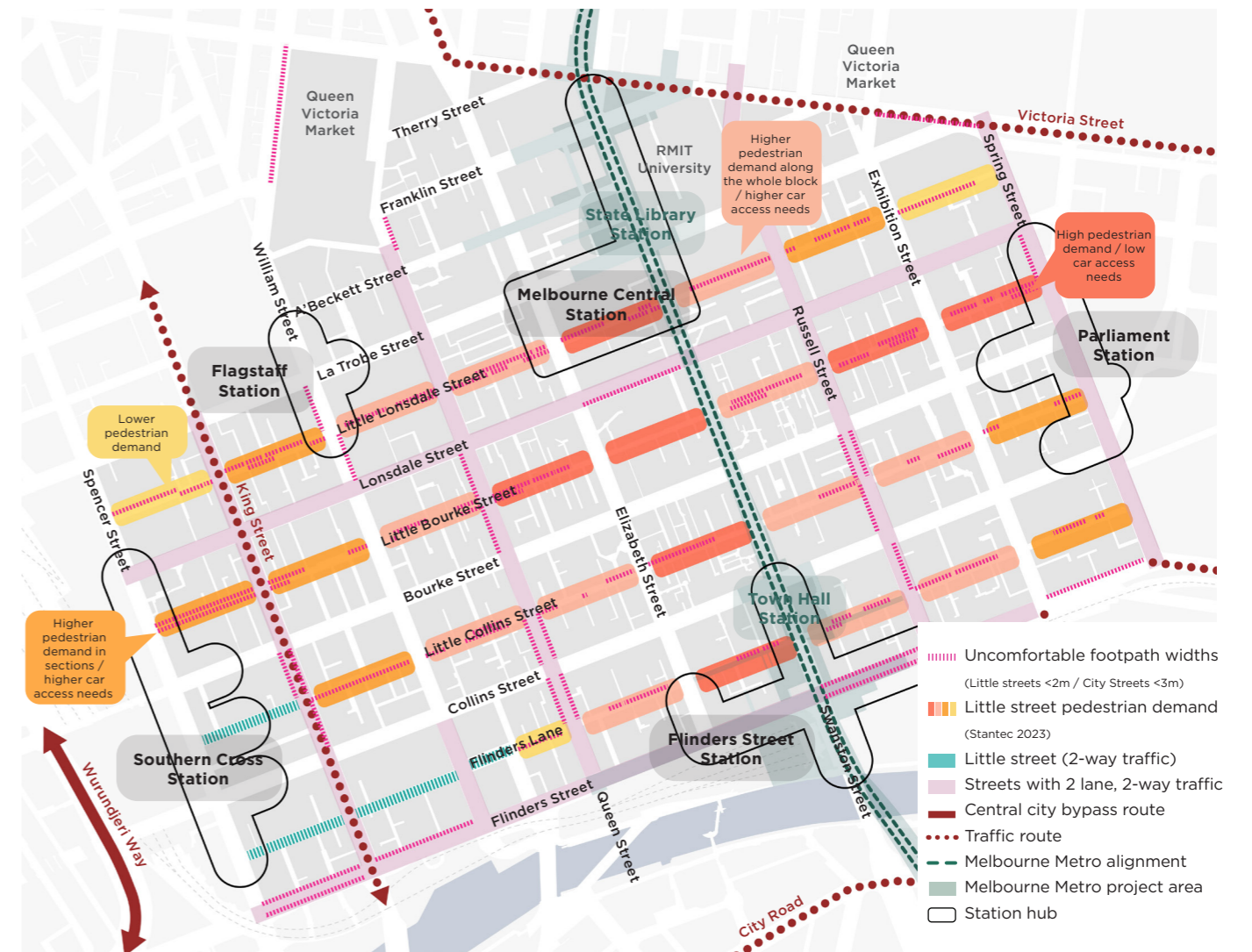

Additionally, a comprehensive and continuous bicycle network, including safety improvements at intersections, is essential in encouraging more people on bikes, particularly for less confident users, for local trips and to attract people from surrounding neighbourhoods.

Safety and wellbeing

Streets support safety and wellbeing by catering to a spectrum of user requirements across genders, ages, cultures, life stages and abilities. Ensuring everyone feels safe to occupy public spaces, and can access the same places and opportunities, is crucial to fostering diverse environments.

In the Hoddle Grid an interplay of physical and operational factors help shape inclusive environments and attractive station precincts. Facilitating safe, comfortable and accessible journeys includes consideration of topography, vehicle speeds, tram stop arrangements, pedestrian crossing times, lighting, shade and cooling, surface treatments and integration of non-visual wayfinding.

The needs of women, girls and gender diverse people, have consistently been neglected from city shaping processes, and has resulted in under provision of infrastructure and facilities. There is a need for a more nuanced understanding of safety as a spectrum of experiences, and to more fully understand the many factors that contribute to feeling safe.

There is enormous opportunity to trial new methods of engagement and gather new insights from a diverse range of users to ensure public spaces support individual and collective wellbeing. Streets that support events, parades and demonstrations are also important in fostering a sense of community, belonging and identity.

Servicing the needs of the city

The Transport Strategy 2030 identifies central city bypass routes to help reduce through-traffic in the Hoddle Grid, improve amenity of places and free up space for more efficient modes and other uses. Importantly, vehicles are still required to serve local functions, to fulfil servicing requirements for businesses and residents, to accommodate emergency vehicles and to provide ease of access for people who rely on vehicles for mobility. Freight trips also provide significant contribution to the Hoddle Grid.

Efficient and flexible management of parking can help support these local access needs while also supporting high quality public realm, promoting different uses over the day and night, and helping to rebalance streets towards active and sustainable modes. Ride share also offers opportunities to service the city by reducing parking demands and encouraging more efficient travel.

STREETS FOR A THRIVING ECONOMY AND UNIQUE EXPERIENCES

Over the past 30 years, Melbourne's central city has evolved from a commercially-focused centre to a thriving 24 hour mixed use activity hub. This merging of cultural, retail, institutional, office and residential uses contributes to the rich and diverse experiences of streets, drawing in a mix of people across the day and night. High quality public realm and open spaces, in addition to efficient and sustainable travel choices, together support a liveable and thriving city economy.

Key directions

- Continue to invest in streets as contributors to the character, function, amenity, comfort, greening and enjoyment of places to support overall economic success and city livelihood.
- Contribute to the activation and amenity of important destinations by reducing through vehicle traffic.
- Support the walking economy, outdoor dining, public art and events while retaining essential site servicing and loading outside of peak activity periods.
- Test alternative activations and trials in kerbside space to understand viability for more permanent ongoing programs, such as extended outdoor dining.
- Transition successful temporary public realm interventions to more permanent features.
- Deliver new public open space in streets aligned to significant civic or cultural destinations.
- Explore opportunities for integrated public art to emphasise diversity and creativity including recognition of Aboriginal people and culture.
- Re-imagine the design of long-term outdoor dining parklets and rejuvenate parklets in thriving hospitality precincts.
- Continue to support access for loading, servicing and deliveries for business.

Key documents

Key Council documents:

- Draft City Spatial Plan (July 2022)
- Economic Development Strategy 2031
- COVID-19 Reactivation and Recovery Plan: City of the Future September 2020
- Open Space Strategy 2012
- Health and Wellbeing Action Plan 2021-25
- CBD Lanes Built Form Review (August 2005)
- Outdoor Cafe Guide and Outdoor Dining Guidelines
- Urban Forest Strategy 2014

Other key documents:

1. Parklet and Extended Outdoor Dining Program Evaluation (Urbis 2021)
2. Open Space for Everyone (DELWP 2021)
3. Contribution of different modes of transport to city recovery (Urbis 2022)

Figure 10: Existing conditions



Strategic context

Place attraction and city activation

The city derives its value from its ability to attract a range of workers, businesses, residents and visitors. A dense clustering of unique and amenable precincts, places and experiences cumulatively contribute to Melbourne's overall appeal as both a capital city and a collection of diverse neighbourhoods.

Streets play a fundamental role in celebrating place character and in supporting the variety of activities required for a thriving economy. This includes acknowledging cultural layers, supporting vibrant dining precincts, providing opportunities for community expression and art, encouraging exchange of information and ideas, and stimulating business and trade.

Streets also hold immense potential to support economic recovery and build resilience before, during and after shocks. The transition from temporary to permanent public realm interventions and programs as part of COVID-19 recovery has trended globally given the wide array of benefits delivered from trials and pilots.

A range of temporary interventions were tested across the city including: extended outdoor dining, intermittent laneway and streetscape closures, temporary footpath widening, little streets transformations and adjustable protected bike lanes. These delivered a suite of economic, social and environmental benefits, and have informed new ways forward.

In addition to more vibrant streets, an evaluation of the City of Melbourne's extended outdoor dining program identified a suite of economic benefits¹ including:

- **generating revenue for businesses** (75% of businesses generated at least an additional \$1,642 per week from their extended outdoor dining areas)
- **positive flow-on benefits for the wider economy** (The program generated an additional 100 jobs of which 64 were in the food industry plus \$20.6 million in broader economic benefits)
- **more permits for outdoor dining** (An additional 852 outdoor dining permits were issued during the initial 6 month program)
- **a continuing program legacy** (The City of Melbourne has determined to continue the program beyond the initial period of 30th June 2021).



Image 11: Princess Theatre Forecourt

Formerly a service lane on Spring Street, the forecourt provides a safer and more comfortable space for both pedestrians and theatre-goers, reduces congestion in the area during peak show times and creates a space to meet, gather and dwell.

Open space and trees for prosperous places

The city is surrounded by large, green public parks offering a range of recreational, social, economic and environmental benefits for the city. As identified in the Open Space Strategy, there are opportunities for new public open space within the Hoddle Grid to service a dense and growing population.

Many streets are suited to accommodate new open space, while balancing transport, servicing and other street requirements. Princess Theatre Forecourt is an example of how street space can be reconfigured to provide new public open space that benefits surrounding land uses and popular destinations.

The social and environmental benefits of open spaces are widely recognised. In addition, equitably distributed and high quality open space can also deliver substantive direct and indirect economic benefits² including:

- **attracting visitors** and increasing expenditure in the city
- **creating and sustaining jobs** through a variety of industries including land management, tourism, recreation, creative arts and more

- **increasing value of property** through open space proximity
- **health savings** through connected open space that allows for walking and cycling, and reduces congestion, spending on infrastructure and vehicle operating costs.

Additionally, the Urban Forest Strategy identifies economic benefits attached to urban forests, further supporting the case for green open space and tree-lined streetscapes. In the context of streets, economic (and environmental) benefits can include:

- reducing energy costs by shading buildings in summer
- increasing property values by enhancing street aesthetics
- avoiding costs of infrastructure damage and renewal through shading assets from harmful ultraviolet rays
- decreasing health costs through connecting people with nature
- marketing the culture and image of the city through attractive and economically-competitive settings
- storing and sequestering carbon.

Maximising economic opportunity through optimised streets

In addition to attracting people to places, the ways that people are able to access these places is equally important. The spatial organisation and operational layers of our streets can support greater mode choice, maximising the number of people coming to the city and increasing the time they spend in it.

As identified in the Transport Strategy 2030, increasing road capacity does not necessarily eliminate congestion and oftentimes increases vehicle volumes. This is an unsustainable model of street design in an already constrained and contested city environment.

Sustainable modes (walking, biking/scootering and public transport) are the most efficient way of moving large volumes of people. Currently, 58 per cent of trips to the central city, and 94 per cent of trips around the city, are by sustainable modes³. Moreover, the opening of Melbourne Metro is expected to see a further mode shift towards public transport, and a 7 per cent shift for bicycles and scooters³.

It's therefore important that we allocate street space to meet anticipated demands and to maximise economic value. A person walking to the central city makes the greatest contribution to the central city economy compared to other modes³.

To a lesser degree, cars and trucks that have a destination also provide an economic contribution, but cars and trucks that simply travel through the city without stopping do not provide a benefit³. Additionally, the cost of providing for cars and trucks, through associated land and infrastructure requirements, far exceeds other transport modes which are more space-efficient and require less infrastructure³.

As we look to the future design of our streets, we must use space wisely and efficiently. While vehicle access needs to be maintained for business, loading, local and emergency purposes, sustainable modes provide the greatest investment opportunity to productively move people and goods.

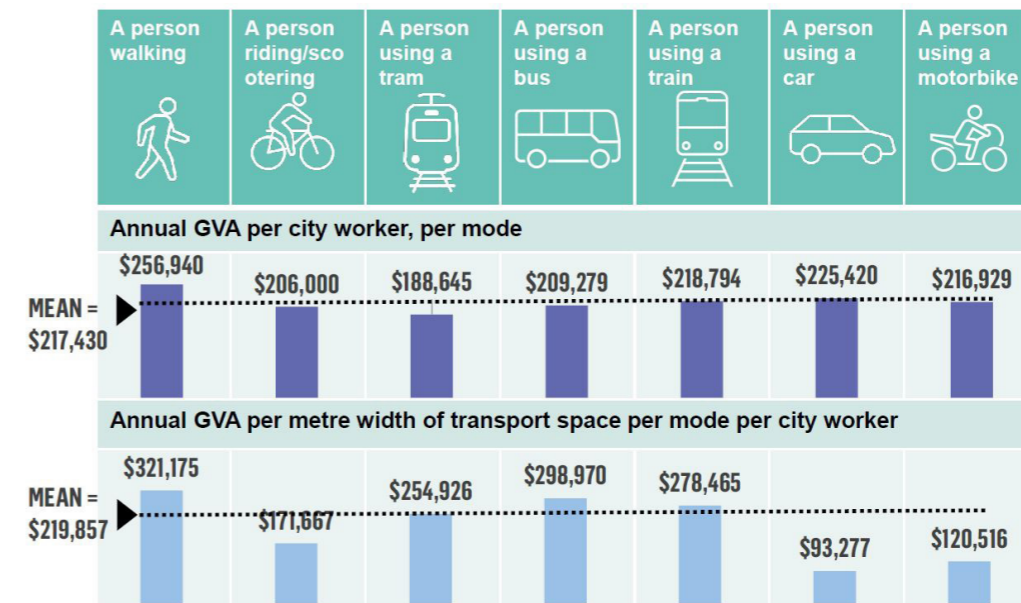

Figure 12: Annual GVA per worker travelling to the central city, by mode³

Gross Value Added (GVA) is 'one way of measuring economic output to measure the contribution made to the economy by individual producers, industries, sectors or regions³. Transport enables economic growth and 'brings in the resources and products that are required to produce GVA³.

STREETS FOR A RESILIENT WATER CATCHMENT

The impacts of climate change, including extreme rainfall and flooding, are often felt more prominently in urban areas. While street space is constrained there is still great potential to capture and reuse rainfall to not only mitigate flooding but to remove pollution and support our urban forest.

Key directions

- Reduce stormwater run-off by reallocating street space for Water Sensitive Urban Design suited to the conditions of the street including but not limited to permeable paving, raingardens and passively irrigated tree pits.
- Increase number of water sensitive urban design initiatives such as permeable surfaces for bike lanes.
- Meaningfully integrate green infrastructure to absorb rain and prevent flooding, including adoption of nature-based solutions and 'Sponge City' approaches.
- Holistically account for all components of the water cycle. This includes using stormwater to reduce urban flooding and improve health of waterways.
- Ensure street upgrades have no adverse impacts on flooding.
- Seek alternative water sources to passively irrigate trees and support new open spaces.

Key documents

- Draft City Spatial Plan (July 2022)
- Municipal Integrated Water Management Plan 2017
- Climate Change Adaptation Strategy Refresh 2017
- United Nations Sustainable Development Goals: City of Melbourne Voluntary Local Review 2022
- Elizabeth Street Catchment Integrated Water Cycle Management Plan 2015
- Central City Urban Forest Precinct Plan 2013-23
- Green our City Strategic Action Plan 2017-21
- Nature in the City Strategy 2017

Strategic context

The Hoddle Grid has a history of flooding events. The highly developed nature of the city means that rainwater tends to run-off towards low lying areas within catchments leading to localised flooding. A high proportion of streets are made up of impermeable surfaces which contributes to polluted water entering waterways, erosion of river banks, damage to habitats, flooding and impacted tree health.

Often this has meant that drainage systems can be easily overwhelmed. There is now a focus on integrated catchment-wide approaches including storing water at ground level rather than relying solely on underground drainage.

Elizabeth Street was formally known as Williams Creek and is a natural low point that is prone to flooding during intense rainfall events. Currently only 17 percent of the drainage catchment is considered permeable which means most stormwater flows directly to the Elizabeth Street main drain rather than being absorbed into soils. Streets within the Hoddle Grid can be designed to alleviate the negative impacts of stormwater through increased permeability and additional flood storage. The Elizabeth Street Catchment Integrated Water Cycle Management Plan seeks to achieve 40 per cent permeability in the catchment by 2030.



Image 13: Example of porous bluestone paving (Collins Street)

Figure 14: Existing conditions

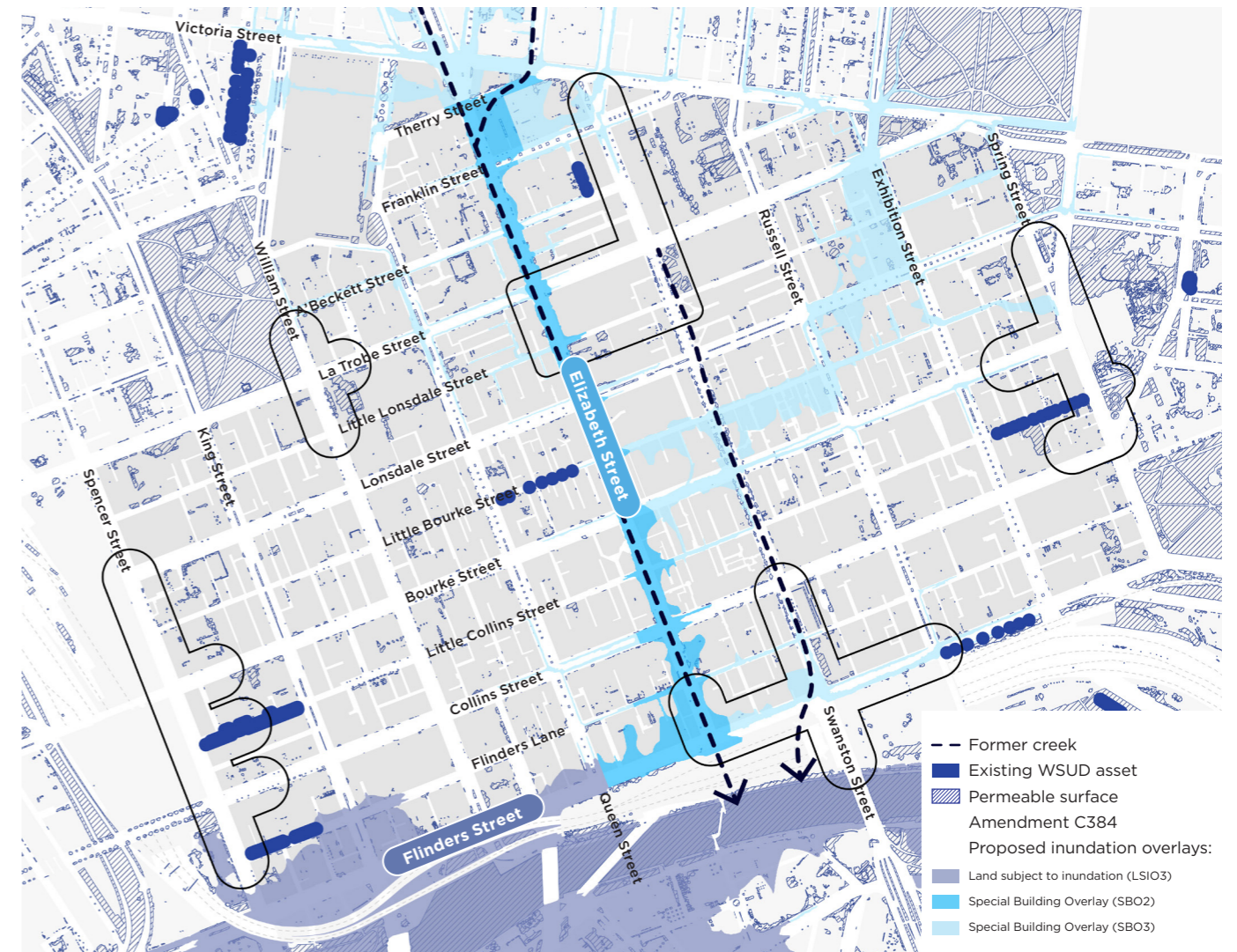

Water Sensitive Urban Design

Water Sensitive Urban Design (WSUD) is used to improve the water cycle and reduce the volume of stormwater that enters waterways. WSUD for streets can be in the form of raingardens, swales, permeable pavement, stormwater harvesting tanks and tree pits. These interventions can also improve the amenity and beautification of places.



Image 15: Tree replacement soak wells and soil volume (Flinders Street)

The wider streets within the Hoddle Grid are considered to have the greatest potential to reallocate street space for WSUD, although there may be some opportunities in little streets to adopt space efficient interventions. Further investigations during the early phases of a streetscape renewal project will assist in determining the appropriate type and extent of WSUD required to meet City of Melbourne's strategic targets. Ongoing maintenance considerations of the asset are also key. This could include exploring alternative water sources to support green infrastructure, rather than relying on potable water for irrigation.

Nature-based solutions

A global shift towards nature-based solutions also holds enormous potential in mitigating flooding while also delivering on a number of additional benefits across ecology, health, wellbeing and city economy. Street greening can extend beyond trees to include a number of green infrastructure interventions that help improve the water cycle. Partnerships and collaborative cross-sector approaches can help catalyse innovative solutions for key streets.

STREETS FOR A COOL, GREEN AND DIVERSE ECOSYSTEM

A combination of climate change impacts and population growth is placing escalating pressure on Melbourne's liveability. Streets can do more to contribute to a healthy urban environment through urban forest, biodiversity and greening contributions.

Key directions

- Deliver on the Urban Forest Strategy and Central City Urban Forest Precinct Plan having regard to the overarching principles for new trees.
- Where there is limited space for new canopy trees, widen footpaths and/or deliver kerb outstands between on-street parking or other kerbside uses.
- Enhance urban ecology and establish biodiversity corridors by implementing new understorey planting along footpaths and medians with a focus along the wider streets. Use streets as bio-links between larger green spaces to enhance ecological connectivity.
- Deliver greening in laneways and little streets suited to the specific conditions of the place to assist with urban cooling and amenity. Consider a variety of ways to deliver greening beyond trees, including green walls, green facades, green rooftops and permeable, vegetated surfaces.
- Deliver raingardens and other landscape oriented WSUD interventions in optimal locations.
- Advocate for increased vegetation on private land interfacing streets including new developments, civic destinations and heritage sites.
- Significantly increase the extent of understorey planting, particularly along the wider streets to foster connections amongst people, plants, and animals. Possible streets include Russell, Exhibition, Lonsdale and Queen Streets which benefit from a central median.
- Provide understorey landscape in little streets aligned with street trees and public seating nodes.

Key documents

- Draft City Spatial Plan (July 2022)
- Central City Urban Forest Precinct Plan 2013-23
- Climate Change Adaptation Strategy Refresh 2017
- Green our City Strategic Action Plan 2017-21
- Nature in the City Strategy 2017
- Urban Forest Strategy: Making a Great City Greener 2012-32
- United Nations Sustainable Development Goals: City of Melbourne Voluntary Local Review 2022

Strategic context

Urban forest

Street trees are important to the function, resilience and amenity of the city. Trees help to address the environmental effects of climate change by cooling temperatures, cleaning air and water, storing carbon, providing habitat and creating comfortable microclimates. Trees also enhance street amenity and experiential quality, which helps attract and retain people. Most notably, some areas of the city with the highest density of people have the lowest canopy cover.

The Urban Forest Strategy has a target to increase canopy cover in the public realm to 40 per cent by 2040. The strategy also aims to remove asphalt and concrete in streets where possible to improve the growing conditions of trees. The Central City Urban Forest Precinct Plan 2013-23 acknowledges that most streets in the Hoddle Grid are heavily used and areas for planting are limited. Trees also help to reinforce street hierarchy, with many wider streets comprising avenues of large plane trees. This approach contributes to the character and wayfinding of the Hoddle Grid.

In more constrained locations, such as little streets or laneways, there are often few or no trees due to the narrow street profiles, restricted solar access, above ground or underground infrastructure. In these streets, small to medium sized trees may be more suitable and at the same time help to contribute to the diversity of the urban forest.

Figure 16: Existing conditions

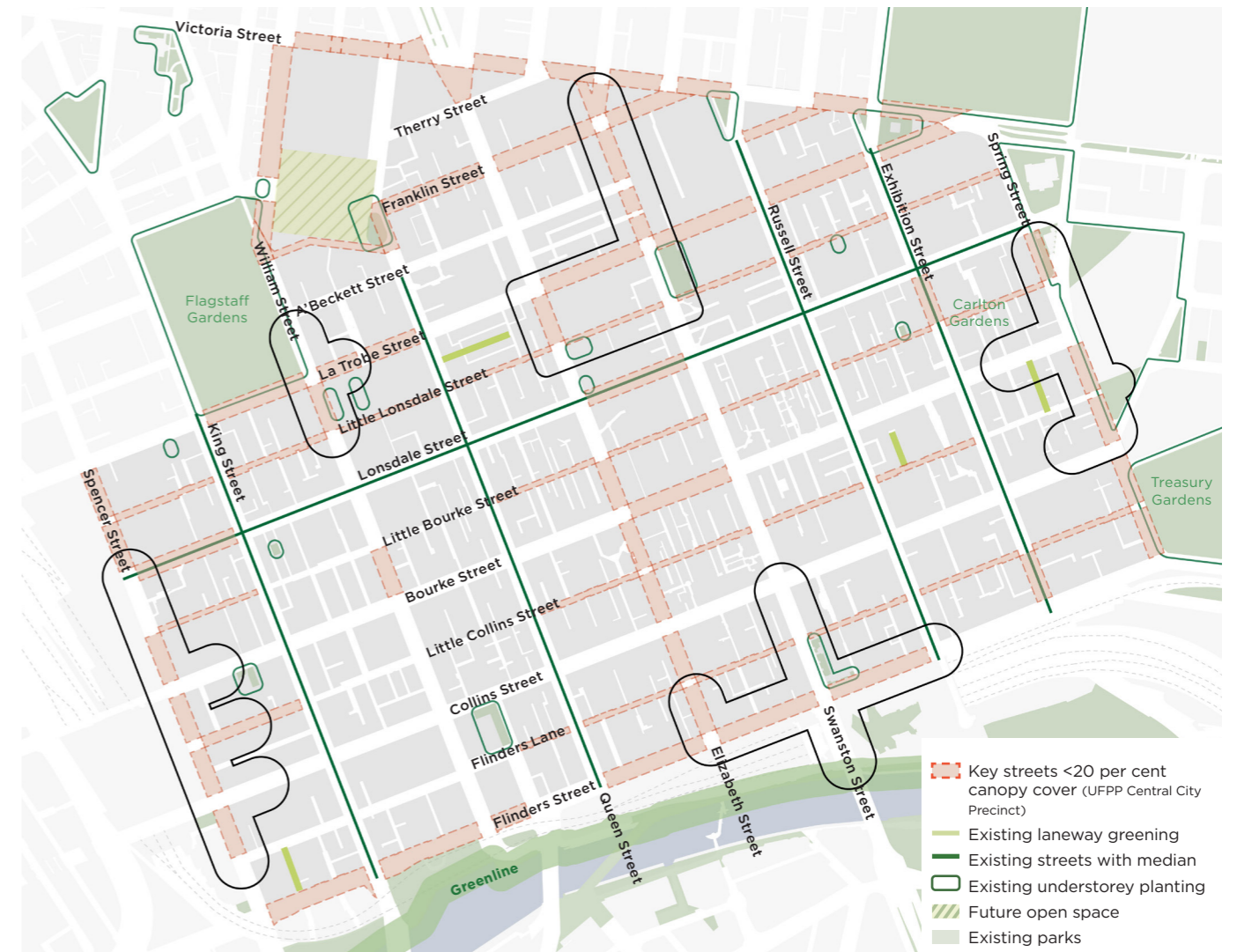

Deciduous trees and no trees are sometimes required to maintain solar access to balance the heavy shadowing of dense built form in the city.

As part of any streetscape upgrade, consideration of urban forest needs should inform early project planning and design to ensure the greatest opportunity of success.

Biodiversity and greening

Enhancing the greening of streets in the Hoddle Grid increases the resilience of the urban forest and helps to cool our city. The greening and cooling of streets across the Hoddle Grid supports more comfortable active travel as a method of reducing carbon emissions.

The Nature in the City Strategy 2017 seeks to increase understorey plants on City of Melbourne land by 20 per cent by 2027. Not only does landscape provide significant ecological benefits, access to healthy, biodiversity-rich, green spaces have been linked to the improved health and wellbeing of people. Opportunity exists for all types of streets to integrate understorey plants to reflect the unique character of Melbourne and provide enticing places to spend time.

The Green Your Laneway program is one initiative focused on repurposing space in laneways for landscape. Greening laneways can deliver many benefits by providing attractive spaces, reduce flooding and offering leafy places to shelter from hot days. Opportunity exists to deliver additional greening in streets and laneways to support the amenity of pedestrian links or outdoor public uses.



Image 17: Green Your Laneway program (Meyers Place)

STREETS FOR AN INTUITIVE AND EVER-CHANGING CITY

Melbourne's appeal as a global destination and liveable neighbourhood is in great part due to our innovative and diverse public spaces and streets. An important attribute of streets as public space is their ability to adapt as the needs of the city change.

Key directions

- Investigate opportunities to procure and install innovative sensing technologies that enable the flexible and versatile use of kerbside space.
- Continue to establish mechanisms to facilitate the safe use of dockless scooter and bike technology while improving amenity outcomes.
- Continue to embed new and emerging sensing technologies as part of future street upgrades to enhance user experiences and optimise maintenance.
- Coordinate pilot projects with other street upgrades to trial new technology such as 5G infrastructure with the potential to roll-out more broadly in the future.
- Investigate opportunities for digital technology to provide a passive revenue source for Council to support the maintenance and upgrade of streets. Partner with industry community and government to coordinate pilot projects.
- Explore options to consolidate and automate waste management to improve pedestrian amenity, particularly in laneways. Spatially restricted spaces can be rationalised to provide greening, sustainable transport and amenity improvements.
- Test and embed low-carbon materials, finishes and processes to optimise streetscape design for a more sustainable future.

Key documents

- Transport Strategy 2030
- Climate Change Mitigation Strategy to 2050
- Waste and Resource Recovery Strategy 2030
- Guidelines for Waste Management Plans 2021
- Inclusive Melbourne Strategy 2022-32
- Draft Parking and Kerbside Management Plan

Strategic context

Use of emerging technologies

Emerging technologies and data collection are becoming a larger part of the urban realm through:

- their physical presence in public spaces
- their uses in city operations and business practices
- their functional outcomes for local communities.

It is increasingly important for City of Melbourne to uphold the Inclusive Melbourne Strategy 2022-32 pillars to ensure their design, testing, installation, use and maintenance leverage universal design principles, and uphold the community values of accountability, transparency, trust, privacy and care.

Versatile kerbside space

Flexible kerbside space in the Hoddle Grid has enormous potential to optimise the use of streets in areas where the demand for street space is high. Uses that can be supported in kerbside space include loading bays, ride share pick up and drop off, bike lanes, additional pedestrian space or potential non-transport uses such as outdoor dining or public space. Information can be communicated through mobile applications, digital signs and dynamic road surfaces to manage safety and clearly communicate the function. Similarly, smart and automated systems can assist with more efficient logistics and waste management.



Image 18: E-scooter trials in Victoria



Image 19: 'Smart park' uses sensors and other smart devices to collect data on patterns of use and micro-climate in Argyle Square, Carlton. These insights help identify opportunities for more supportive, inclusive and comfortable spaces.

Last mile transport and micromobility

Micromobility has become a widely adopted means for people to move about the city efficiently. Usually trips made by these modes are short, and such modes can be either owned privately or borrowed as part of a short-term, self-service scheme. This can assist locals in moving around but also provide a convenient means for visitors to explore the city. Similarly, last mile transport refers to the last part of a journey where people or goods reach their final destination. This can include use of dockless electric scooters to reach a station or tram stop. Given this broad user base, currently and into the future, it is important that streets are planned to manage this. This includes facilitating safe journeys while also ensuring that when parked they do not block footpaths and impede pedestrian movement.

Leveraging data and technology

Data and technology offer the opportunity to differentiate our place experience and manage different uses of streets at different times. It is crucial that data and technology do not conflict with the function or amenity of streets, but rather serve to complement its use and character.

Across the city, an existing network of sensing technologies collect data. This includes pedestrian and cycling counts, on-street parking, micro-climate and furniture usage. Targeted data collection can give a better evidence base about who, where, why and how the city is being used, and catalyse change, inform choices, enhance service efficiency, and promote place activation.

This data has enormous potential to inform planning, strategy, operation, as well as assist in monitoring and measuring impact to iterate urban realm design. This evidence-based approach ensures that we are not only addressing a spectrum of user needs, but also creating an intuitive city for everyone.



Image 20: The Social Spaces pilot seeks to explore how data can inform design by using sensors to monitor usage. The bench is one of three winning projects selected as a pilot and is located on a median on Drummond Street, Carlton.

Similarly, technological infrastructure holds potential to improve safety and transport functions, reduce maintenance costs and energy consumption, and assist Council to make informed decisions. Prototyping new street materials and innovative construction systems can also make maintenance and future changes easier.

The city has a role in inviting, collaborating, and using emerging technologies to achieve positive change, including through pilot and experimental studies with universities and industry who are at the forefront of this work.

Additionally, the role of 5G infrastructure in cities is becoming increasingly important as City of Melbourne seeks to deliver high quality, fit-for-purpose streets that respond to social, economic and environmental needs of the city. The integration of 5G and other future connectivity types in streets will enable the implementation of future technologies such as intelligent transport systems and smart energy systems to improve the safety and function of streets while reducing congestion and emissions.

Optimising waste management

Rapid growth and consumption patterns require more efficient ways of managing waste in our cities. Behavioural shifts, integration of circular economy principles, better regulations, governance and planning, and physical infrastructure can all support better waste management while also improving pedestrian movement and amenity.

There is opportunity for streets to support a shift towards more consolidated and automated waste management. The City of Melbourne currently has five garbage compactors and numerous recycling hubs throughout the central city area to minimise amenity issues on streets. This is particularly important for laneways that typically have constrained widths and play an important permeability and place role in the Hoddle Grid.

PART 1

STREET TYPES

STREET TYPES OVERVIEW

Our cities comprise a diverse network of streets of varying sizes, functions and characters. Each street fulfils multiple functions including connecting people to destinations and supporting activation. Streets also share common features which can be classified into distinctive street types.

Street types share similar objectives, design principles and opportunities for improvements. Crucially, defining street types can assist planning and design professionals, developers, government and community to achieve aligned approaches to street interventions and design solutions.

Movement and Place Framework

The Movement and Place Framework (Department of Transport and Planning 2019) is a strategic network planning tool that organises street types by their 'place' and 'movement' roles.

The 2030 Proposed Integrated Network of the Transport Strategy 2030 adopted the Movement and Place Framework to ensure alignment between Victorian and local Government objectives for Melbourne's future transport network.

The Movement and Place Framework recognises that streets perform multiple functions. They not only move people from point A to B, via different transport modes, they are also places and destinations in their own right. Streets often have competing demands. It is important to find the right balance between movement and place.

In the simplest of terms, movement and place can be described as follows:

Movement

Movement classifications represent the mix of transport links that are required to support the overall demand for movement across a network. Movement classifications define the transport needs of a street strategically and the degree to which various modes need to be prioritised.

Place

Place classifications help define the level of a street's strategic significance. The place classification responds to and helps shape land use, and is a function of physical characteristics, historic uses, heritage and cultural layers.

Given both the capital city and local role that streets in the Hoddle Grid play, it is important that they support a broad range of users, uses and activities.

This report has aligned with the Movement and Place Framework and the 2030 Proposed Integrated Network of the Transport Strategy 2030 to localise the street types and principles for the Hoddle Grid.

Figure 21: Network classifications matrix - a system of classifying transport links and hierarchies (Department of Transport and Planning 2019) Street types for the Hoddle Grid are annotated on the image to demonstrate alignment with the Movement and Place Framework.

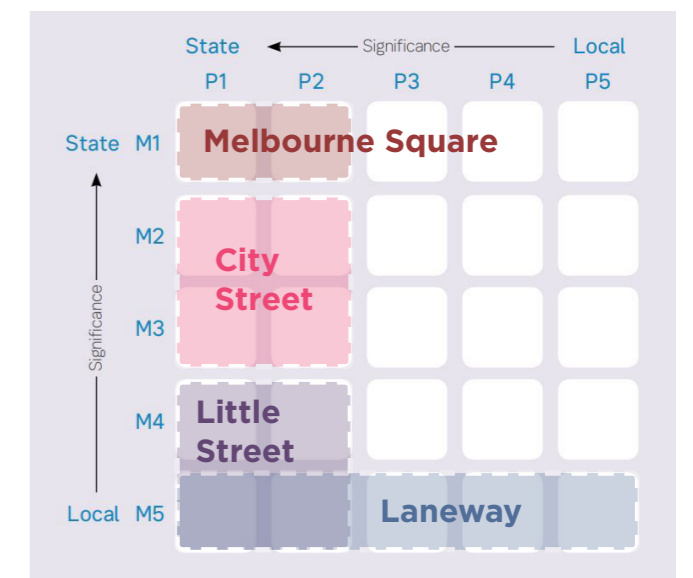

STREET TYPES OVERVIEW

The Hoddle Grid is comprised of distinct street types, all with significant place functions.











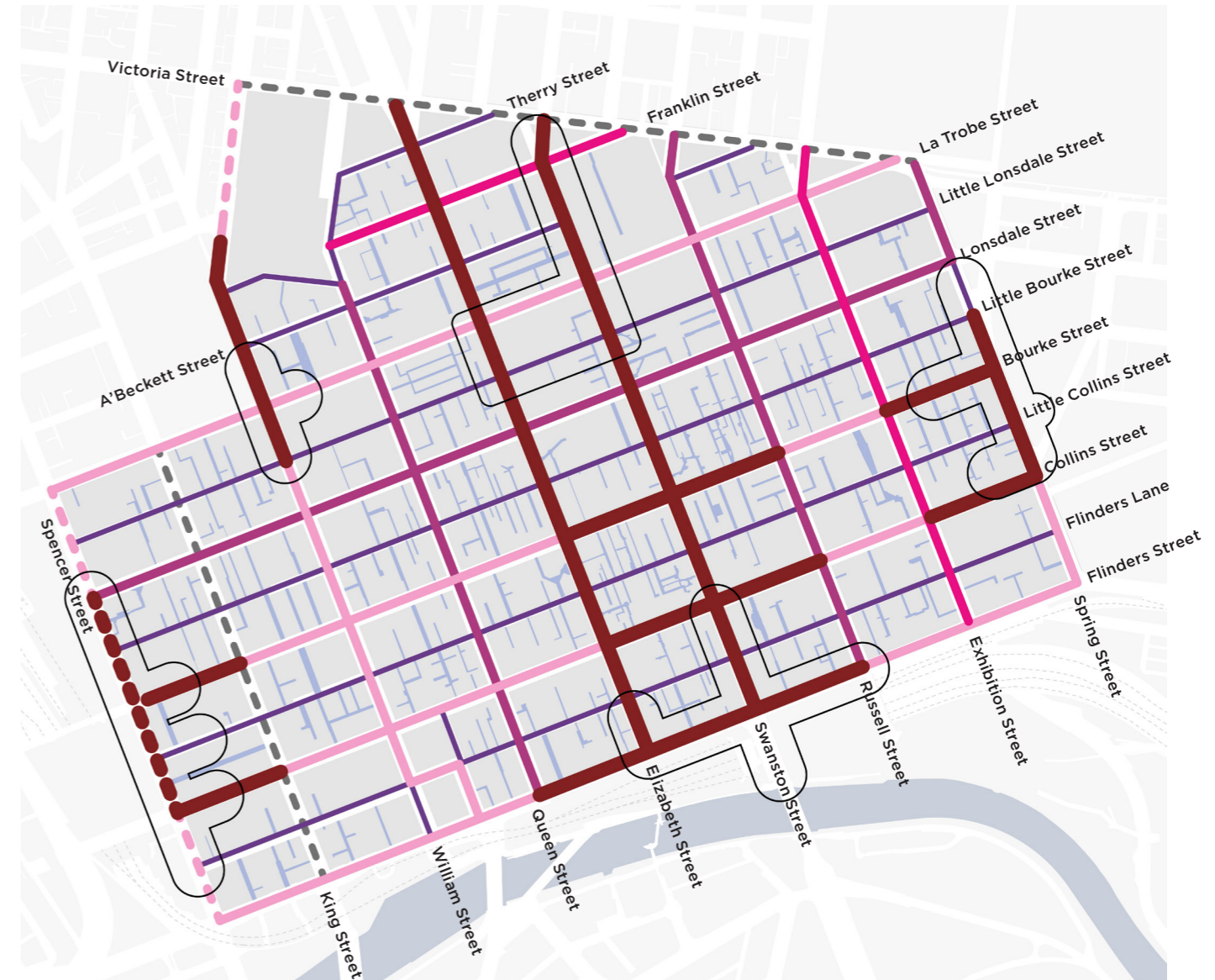

STREET TYPE	DESCRIPTION
 Melbourne Square	<p>Melbourne Squares serve as gateways to the city, centered around transport interchanges and prominent civic destinations. They are typically intense and lively places at all times of the day and must support high pedestrian flows.</p> <p>These streets provide a strong sense of arrival, while serving a multitude of functions for residents, workers and visitors alike. These streets showcase Melbourne's unique character, in particular Melbourne's iconic tram network, prominent heritage buildings and connections to popular retail and dining precincts.</p> <p>A significant amount of change is anticipated to occur in Melbourne Squares over the coming years in response to the Melbourne Metro Tunnel Project and tram stop upgrades.</p>
 • With trams  • With buses  • With bikes	<p>City Street</p> <p>City Streets are critical movement corridors. They are often experienced in their entirety, moving north-south or east-west from the periphery of the city. These streets must support multiple transport modes and high place functions.</p> <p>While all City Streets have a strong movement function, the varied transport they support and adjacent land uses create a variety of conditions. There are three distinct city street sub-types within the grid each prioritising different modes: trams, buses and bicycles.</p>
 Little street	<p>Melbourne's little streets are significant places that support small businesses and other fine grain uses. While they do not have a high movement role, they provide crucial servicing and loading to support residents, commerce and trading.</p> <p>Little streets are distinctive in character and activity. Some little streets form part of cultural, dining and retail precincts including Chinatown on Little Bourke Street and Flinders Lane. These streets are popular destinations; facilitating high volumes of pedestrians and accommodating outdoor dining.</p> <p>Little streets have considerable capacity for renewal due to no public transport infrastructure and low volumes of through-traffic. The Transport Strategy 2030, identifies little streets as optimal locations for the shared movement of people.</p>
 Laneway	<p>One of the defining characteristics of Melbourne is the intricate and diverse network of laneways. Many laneways are celebrated for their important place function, comprising of fine grain uses, street activities, outdoor dining, greening and public art, enabled within a pedestrian-friendly environment.</p> <p>Many laneways also provide a combination of service and loading functions to support businesses, which can sometimes operate at specific times of the day to balance both movement and place needs. The inherent eccentricity of laneways mean there is no one-size-fits-all approach to the design and upgrade of laneways.</p>
 Primary traffic through route	<p>Managed by Department of Transport and Planning (DTP), key streets have been identified to serve important connections to surrounding neighbourhoods and municipalities. These routes will continue to serve a critical role for vehicle through movement.</p>

Figure 22: Street types



Key

-  Melbourne Square
-  City Street with trams
-  City Street with buses
-  City Street with bikes
-  Little street
-  Laneway
-  Station hub
-  Primary traffic through route

- Note:**
- Dotted lines indicate arterial roads managed by Department of Transport and Planning.
 - In addition to King Street and Victoria Street, it is proposed that through vehicle access will be maintained on Lonsdale, Queen, Russell, La Trobe and Exhibition Streets.
 - The street types are a general categorisation of streets with similar design principles. Each street segment is subject to further analysis of contextual circumstances, traffic assessment, feasibility studies and modal priority anomalies to inform detailed street design.
 - Some streets may shift street types from day to night.

DESIGN EXCELLENCE PRINCIPLES FOR STREETS

An overarching set of principles are fundamental to high quality street design. These principles contribute to the ongoing economic, social and environmental success of the central city.



Image 23: Sandridge Bridge

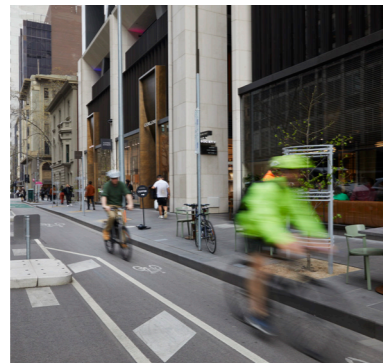

Image 24: Exhibition Street



Image 25: Bourke Street



Image 26: Swanston Street

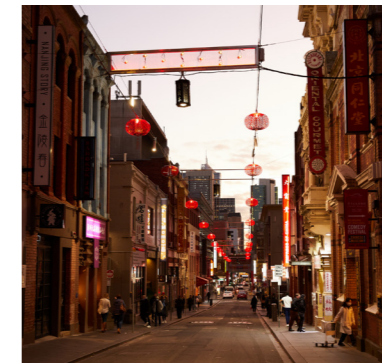

Image 27: Chinatown



Image 28: Princess Theatre Forecourt

Inclusive

Streets in the Hoddle Grid should:

- Foreground designing with Country in collaboration with Traditional Owners.
- Recognise, promote and celebrate the layers of history and the mix of cultures and stories.
- Cater to a spectrum of user requirements through integrated universal design.
- Provide diverse spaces for everyone to enjoy and occupy.
- Maximise opportunities for community agency and expression.
- Support presence and participation of women and gender diverse people in public spaces.
- Integrate commemorative justice for Aboriginal and intersectional communities.

Safe

Streets in the Hoddle Grid should:

- Support low speed environments through speed limit reductions and traffic calming measures.
- Provide well-lit environments and complement 24/7 land uses to improve perceived safety.
- Reduce physical obstacles, declutter footpaths and remove barriers to access.
- Rationalise signage to reduce visual clutter and improve navigation.
- Provide surfaces and transitions that are safe and comfortable for small wheel sizes.

Comfortable

Streets in the Hoddle Grid should:

- Provide comfortable journeys for pedestrians by minimising congestion, clutter and pinchpoints.
- Maximise convenient mid-block crossing points to support walkability and permeability.
- Provide pedestrian amenity, including convenient provision of bins, seating, drinking fountains and shade.
- Support intuitive navigation and wayfinding.

Healthy

Streets in the Hoddle Grid should:

- Integrate sustainable water management interventions.
- Contribute to urban cooling through improved tree canopy cover and increased planting.
- Consider a range of green infrastructure options suitable for the site to positively contribute to urban forest and the water cycle.
- Support biodiversity through vegetation and bio-links.
- Support residential communities and worker populations through provision of high quality open spaces, including integration of recreational and playful elements.

Optimised

Streets in the Hoddle Grid should:

- Serve a variety of functions at different times of the day and enable regular or intermittent closures.
- Prepare and futureproof street space to address emerging projects and anticipated changes.
- Provide flexible space to facilitate special events, parades, festivals and demonstrations.
- Support 24/7 land uses and nighttime activation.
- Provide flexible kerbside space to support loading and servicing needs, and street activities.
- Allow for integration of emerging technologies and low carbon materials.
- Integrate wayfinding hubs to reduce the amount of signage.

Uniquely Melbourne

Streets in the Hoddle Grid should:

- Showcase renowned destinations and complement heritage character through sensitive interfaces and materials, and maximising space for people at frontages.
- Maintain and reinforce key views and vistas to landmarks and landscape features.
- Nurture the character of existing places to provide a range of experiences.
- Explore options for integrating public art and street art.
- Respond to history, memory and identity by engaging with local communities' needs and wants.

STREET TYPE MELBOURNE SQUARE

Melbourne Squares are centered around transport interchanges and prominent civic destinations. These streets support high pedestrian volumes, safe and efficient interchange journeys, while comprising places to gather. Melbourne Squares are iconic destinations, celebrating the quintessentially Melbourne characteristics of the city including the tram network, heritage buildings and outdoor activation.

Mode priorities

Existing and future modal priorities:

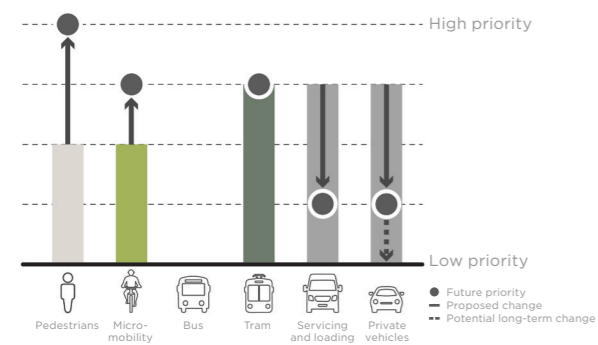

Mode allocation

Proposed typical sections of a Melbourne Square:

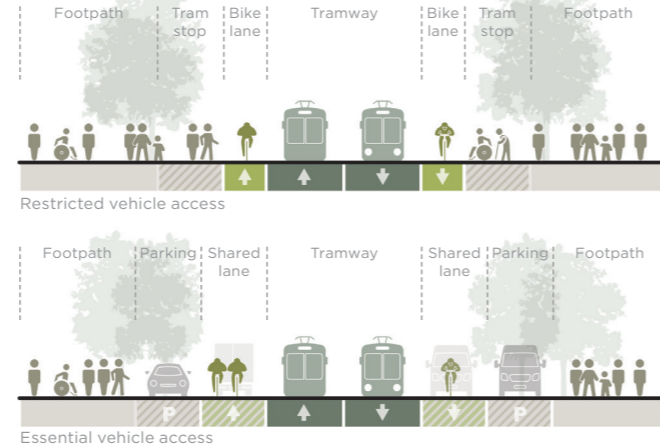

Design principles

Principles for this street type include:

MODE	KEY PRINCIPLES
Pedestrians	<ul style="list-style-type: none"> Enhance the sense of arrival from stations and major tram stops to the Hoddle Grid. Enable a seamless interchange experience with safe and convenient crossing points and minimal delay at signals. Provide unobstructed and comfortable pedestrian movement zones. Declutter the street by rationalising signage and removing footpath obstacles. Provide designated zones for street furniture, landscape and other place-based activations. Increase permeability of pedestrian movement across streets by linking destinations, arcades and desire lines. Manage the interface of pedestrians with other modes through low speeds and varied surface treatments.
Micromobility	<ul style="list-style-type: none"> Improve interchange facilities for people using bikes. Provide safe and continuous bike lanes. Provide convenient bicycle parking aligned with stations and public transport nodes. Designate locations for restricted e-scooter parking to balance user convenience and pedestrian movement.
Public transport	<ul style="list-style-type: none"> Provide high capacity, high amenity tram stops with generous shelter and furnished waiting areas. Integrate tram stops with digital wayfinding and real-time tracking. Ensure tram stops are aligned with station entries. Provide priority signals at intersections to improve tram performance.
Servicing and loading	<ul style="list-style-type: none"> Maintain access for emergency vehicles. Provide intermittent access for loading, waste collection and maintenance vehicles to minimise conflict with efficient transport modes. On-street parking to be determined based on the specific needs of the street informed by the Parking and Kerbside Management Plan.
Private vehicles	<ul style="list-style-type: none"> Reduce through movements for general vehicle traffic, this can be through full closure or partial closure (for example lane restrictions, open in one direction and/or timed access). Avoid on-street parking, except to service DDA needs.

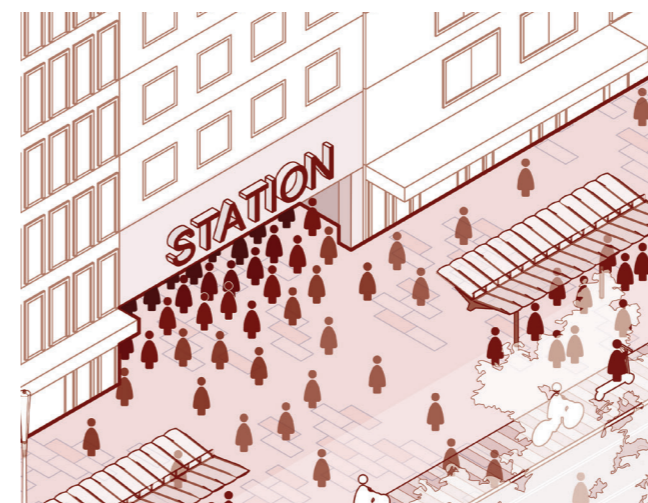
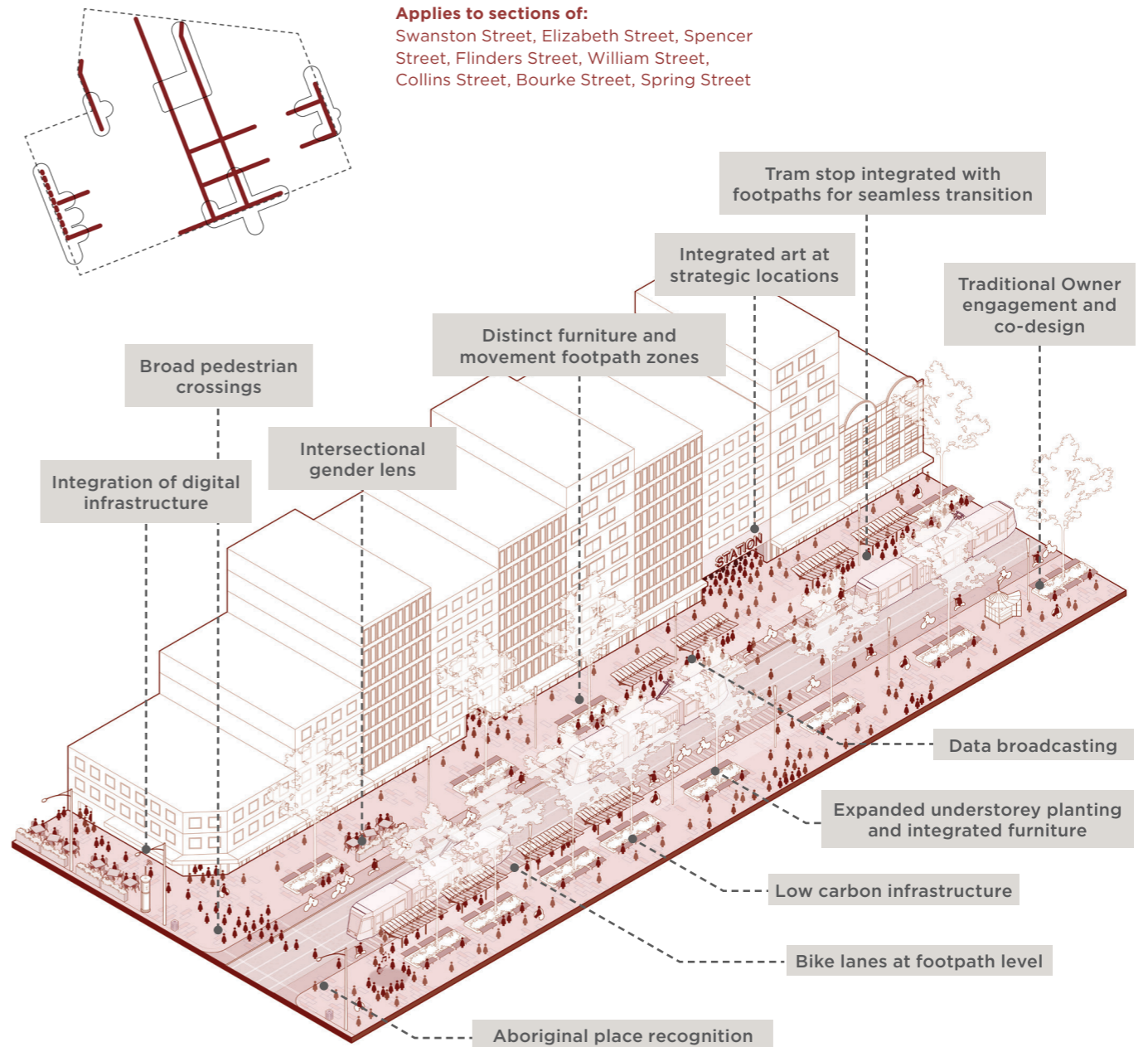

Figure 29: Efficient and seamless interchange journeys between train stations and tram stops



Figure 30: Opportunities for mid-block timed servicing access outside of peak pedestrian periods

STREET TYPE

CITY STREET WITH TRAMS

City Streets with trams move people safely and efficiently. They balance requirements for people, bikes, trams and vehicles, facilitating unimpeded journeys and creating attractive opportunities to dwell.

Mode priorities

Existing and future modal priorities:

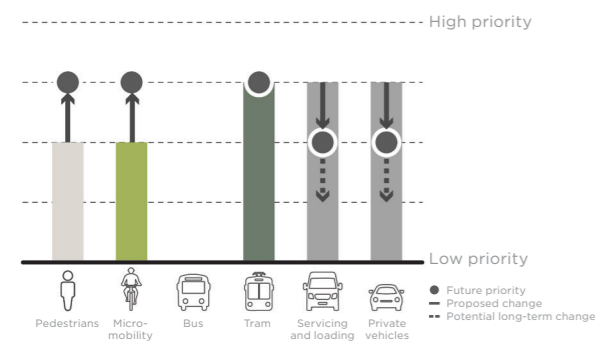

Mode allocation

A proposed typical section of a City Street with trams:

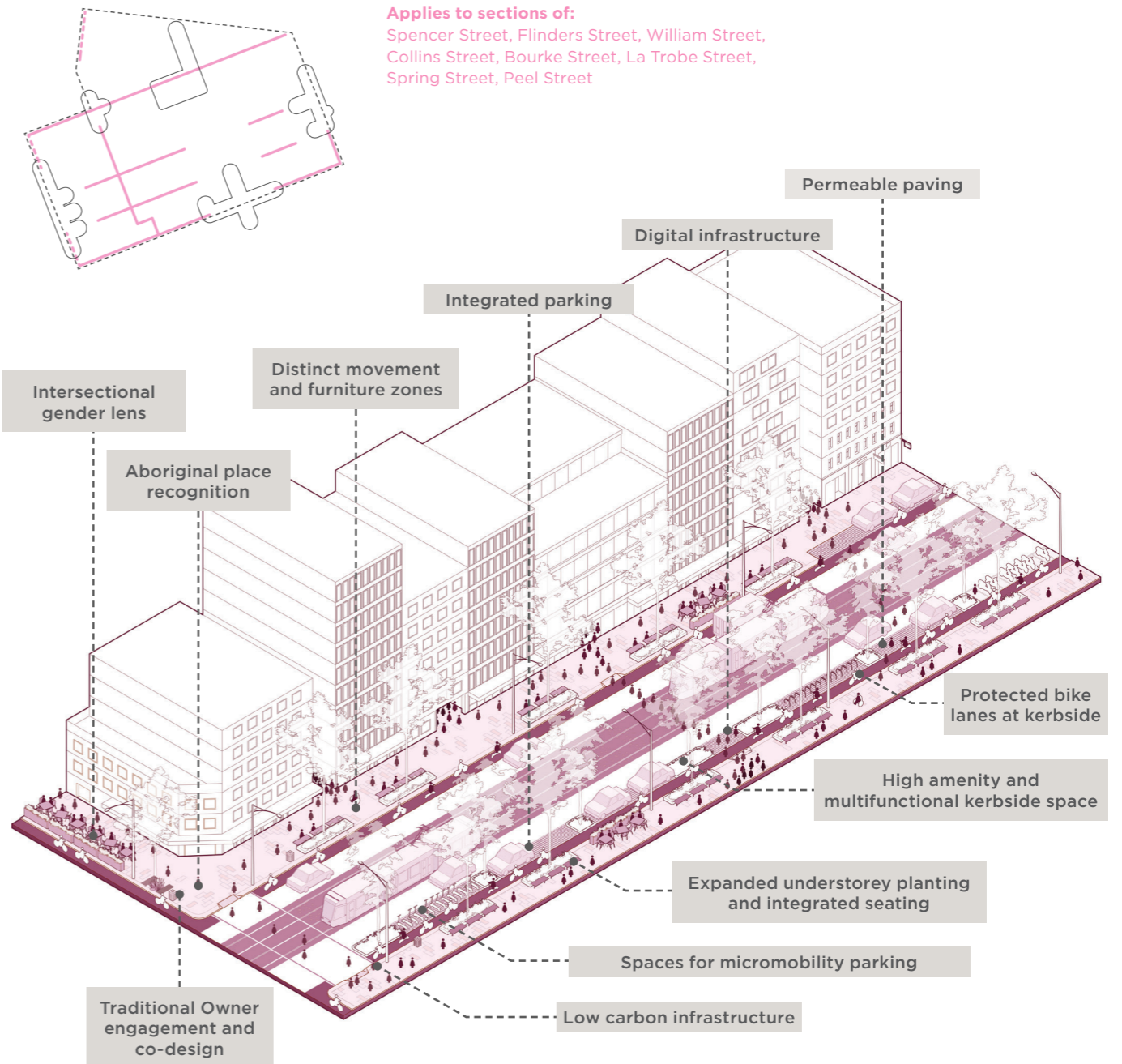
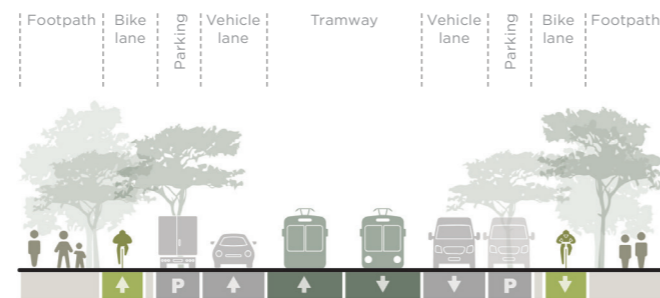

Design principles

Principles for this street type include:

MODE	KEY PRINCIPLES
Pedestrians	<ul style="list-style-type: none"> Provide unobstructed pedestrian movement zones to support an efficient and comfortable pedestrian environment. Provide designated zones for furniture, planting and other place-based treatments. Increase permeability of pedestrian movement across streets by linking destinations, arcades and desire lines. Manage the interface of pedestrians with other modes through low speeds and surface treatments. Declutter the street by rationalising signage, and removing footpath obstacles.
Micromobility	<ul style="list-style-type: none"> Provide safe, generous and continuous protected bike lanes to support high volumes of cyclists. Provide convenient on-street bicycle parking aligned with key destinations. Designate locations for e-scooter parking away from footpaths to balance user convenience and pedestrian movement.
Public transport	<ul style="list-style-type: none"> Provide high capacity and high amenity tram stops with generous shelter and furnished waiting areas. Integrate tram stops with digital wayfinding and real-time tracking. Implement pedestrian crossings to tram stops to each platform end and at key mid-platform locations. Provide priority signals at intersections to improve tram performance.
Servicing and loading	<ul style="list-style-type: none"> Maintain access for emergency vehicles. Provide access for loading, waste collection and maintenance vehicles. Provide on-street servicing and loading in strategic locations to meet the essential needs of building operations.
Private vehicles	<ul style="list-style-type: none"> Reduce through-traffic while supporting local access for essential needs. Provide on-street parking, ensuring appropriate allowance of DDA parking and loading requirements.

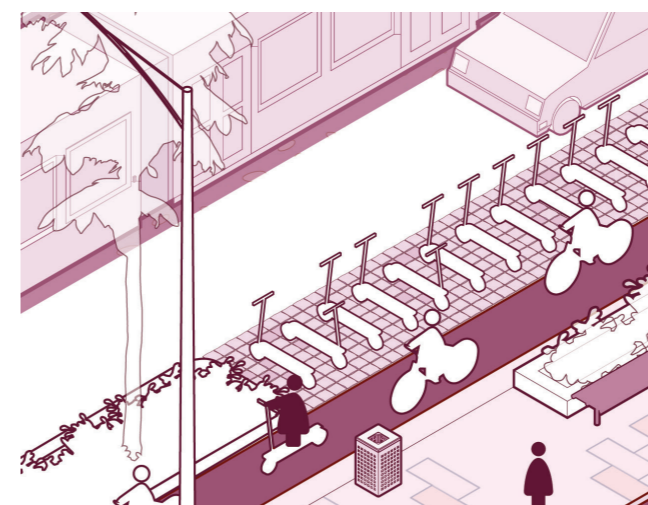

Figure 31: High amenity and multi-functional kerbside space

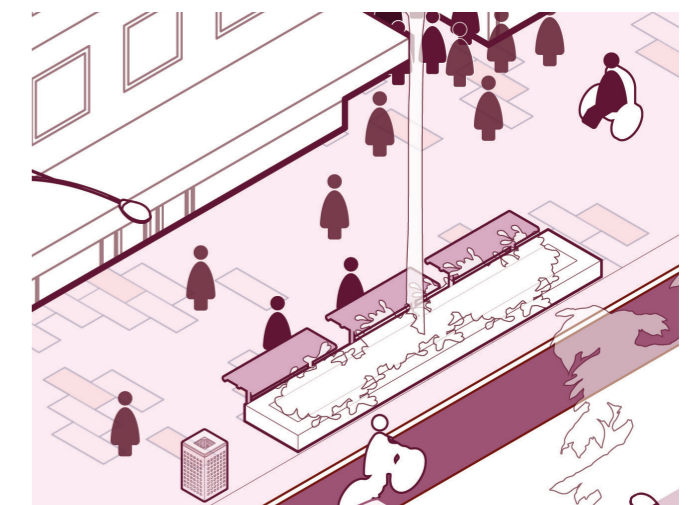

Figure 32: Integrated furniture and planting

STREET TYPE

CITY STREET WITH BUSES

City Streets with buses are high amenity corridors for bus users and pedestrians. They support efficient bus movement and provide comfortable bus stops that are separated from pedestrian movement corridors. These streets support vehicle access to local destinations and businesses, and provide green places for people to spend time in.

Mode priorities

Existing and future modal priorities:

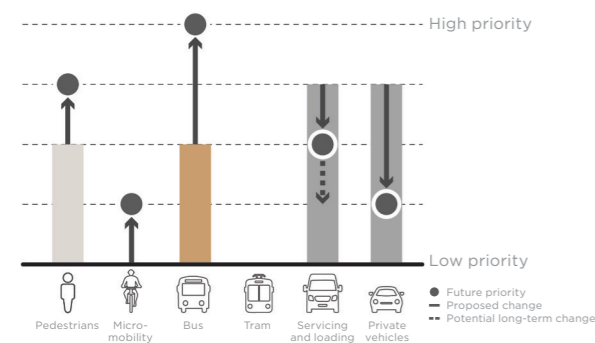

Mode allocation

A proposed typical section of a City Street with buses:

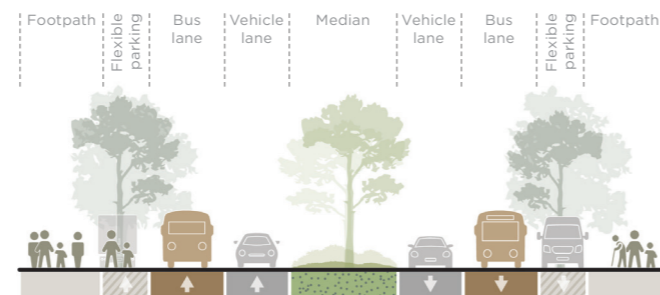

Design principles

Principles for this street type include:

MODE	KEY PRINCIPLES
Pedestrians	<ul style="list-style-type: none"> Provide unobstructed pedestrian movement zones to support an efficient and comfortable pedestrian environment. Provide designated zones for furniture, planting and other place-based treatments. Increase permeability of pedestrian movement across streets by linking destinations, arcades and desire lines. Manage the interface of pedestrians with other modes through low speeds and surface treatments. Declutter the street by rationalising signage, and removing footpath obstacles.
Micromobility	<ul style="list-style-type: none"> Enable local access for micromobility to and from destinations. Deliver lower limits to increase safety for local access micromobility trips. Design lanes to allow for efficient and safe sharing between modes where relevant.
Public transport	<ul style="list-style-type: none"> Provide high capacity and high amenity bus stops with generous shelter and furnished waiting areas that avoid impeding pedestrian movement. Support buses stopping in the bus lane to maximise space for bus passengers to wait, remaining clear of the footpath. Integrate bus stops with digital wayfinding and real-time tracking. Integrate traffic filters and priority signals to improve bus performance.
Servicing and loading	<ul style="list-style-type: none"> Maintain access for emergency vehicles. Provide intermittent access for loading, waste collection and maintenance vehicles to minimise conflict with efficient transport modes. Provide on-street servicing and loading in strategic locations to meet the essential needs of building operations.
Private vehicles	<ul style="list-style-type: none"> Reduce through-traffic while support local access for essential needs. Provide on-street kerb-side parking, ensuring appropriate allowance of DDA parking and loading requirements. Remove median parking to provide space for place-based and environmental treatments.

Applies to sections of:
Russell Street, Queen Street,
Lonsdale Street, Spring Street

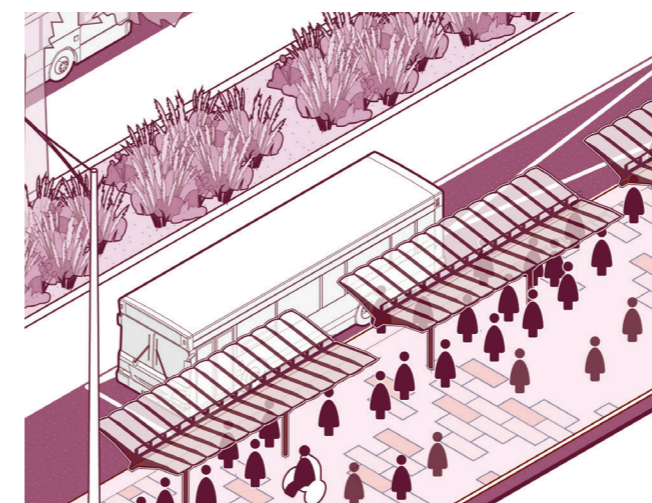
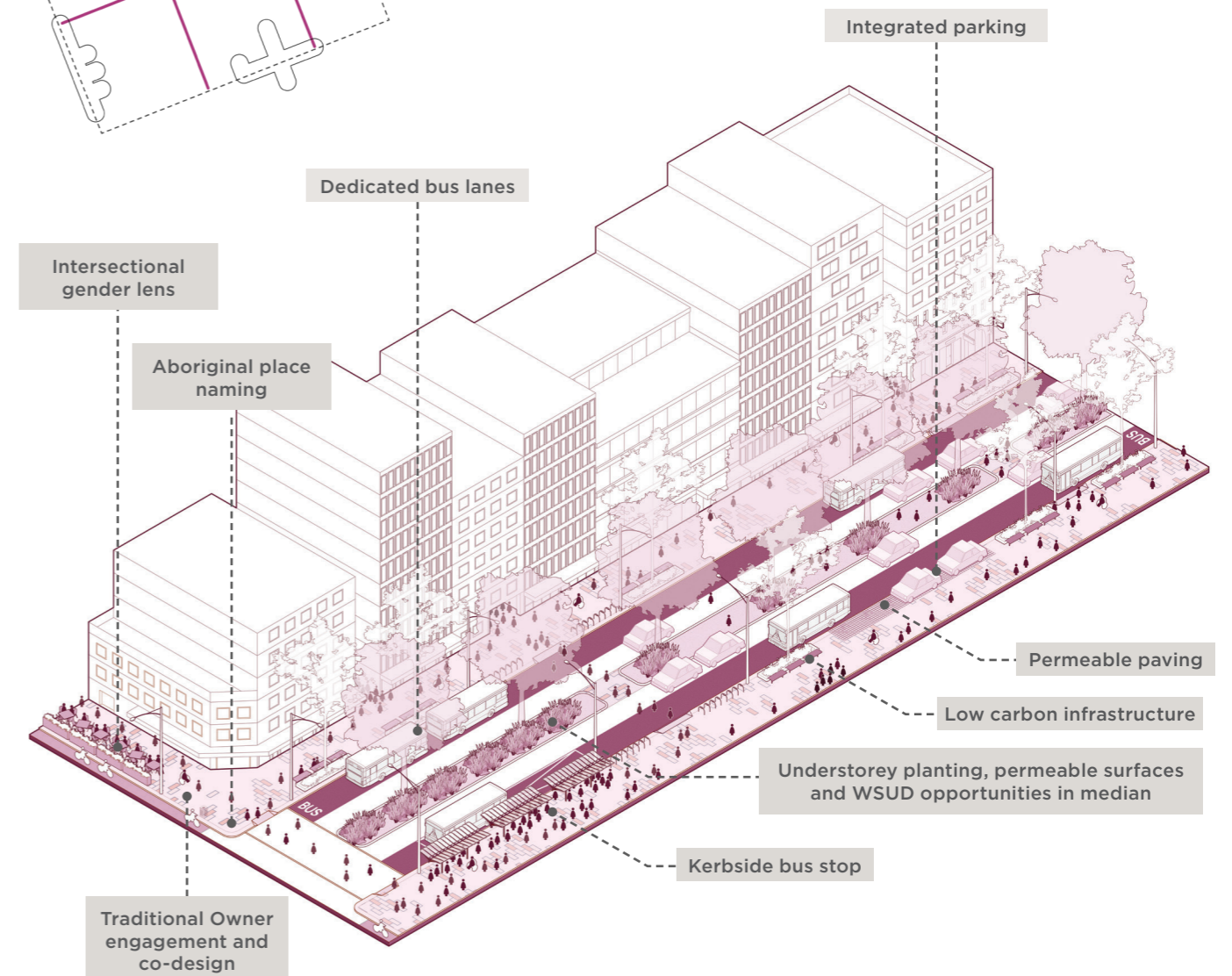

Figure 33: High amenity waiting facilities for bus users



Figure 34: Mid-block crossing points

STREET TYPE

CITY STREET WITH BIKES

City Streets with bikes are safe, active streets that support bike users of all confidence levels. City Streets with bikes provide high quality, protected bike infrastructure, while enabling vehicle access to local destinations and businesses. These streets also provide enhanced greening and open spaces to create high amenity places to spend time in.

Mode priorities

Existing and future modal priorities:

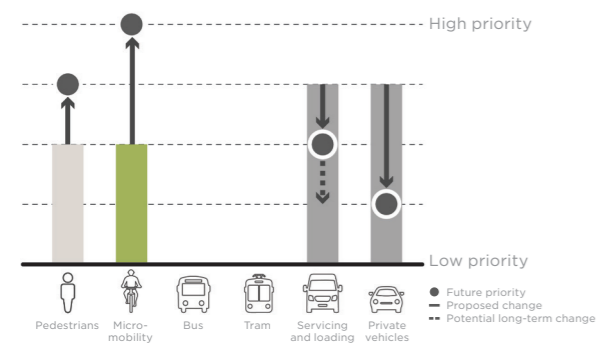

Mode allocation

Proposed typical sections of a City Street with bikes:

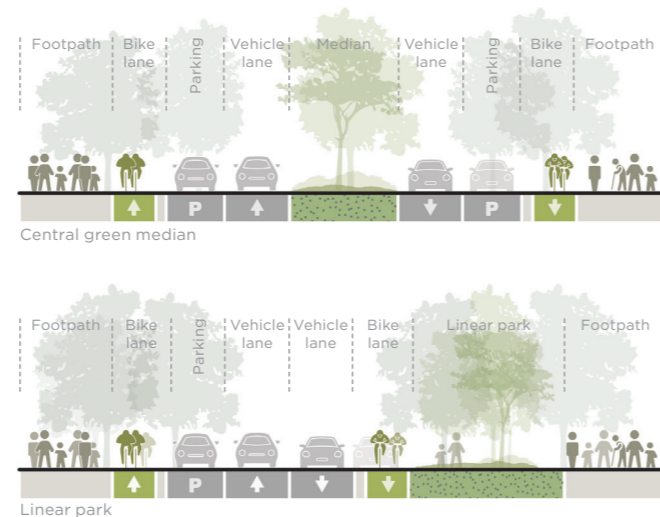

Design principles

Principles for this street type include:

MODE	KEY PRINCIPLES
Pedestrians	<ul style="list-style-type: none"> Provide unobstructed pedestrian movement zones to support an efficient and comfortable pedestrian environment. Provide designated zones for furniture, planting and other place-based treatments. Increase permeability of pedestrian movement across streets by linking destinations, arcades and desire lines. Manage the interface of pedestrians with other modes through low speeds and surface treatments. Declutter the street by rationalising signage, and removing footpath obstacles.
Micromobility	<ul style="list-style-type: none"> Provide safe, generous and continuous protected bike lanes to support high volumes of cyclists. Provide convenient on-street bicycle parking aligned with key destinations. Designate locations for e-scooter parking away from footpaths to balance user convenience and pedestrian movement.
Servicing and loading	<ul style="list-style-type: none"> Maintain access for emergency vehicles. Provide intermittent access for loading, waste collection and maintenance vehicles to minimise conflict with efficient transport modes. Provide on-street servicing and loading in strategic locations to meet the essential needs of building operations.
Private vehicles	<ul style="list-style-type: none"> Reduce through-traffic while support local access for essential needs. Provide on-street kerbside parking in appropriate locations, ensuring allowance for DDA parking. Remove median parking to provide space for place-based and environmental treatments.

Applies to sections of:
Exhibition Street, Franklin Street

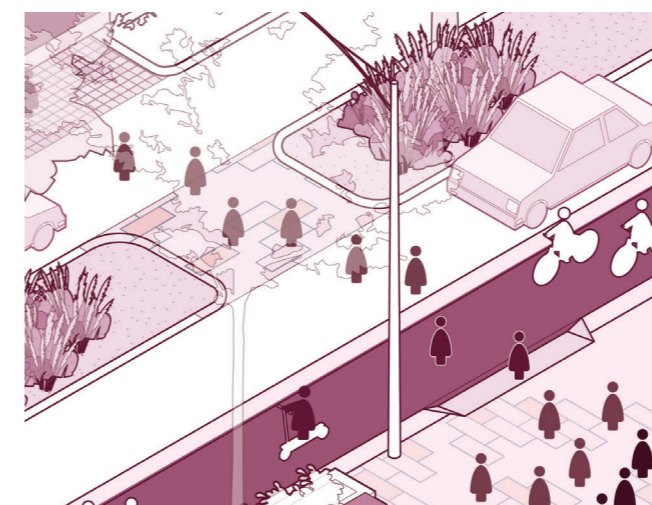
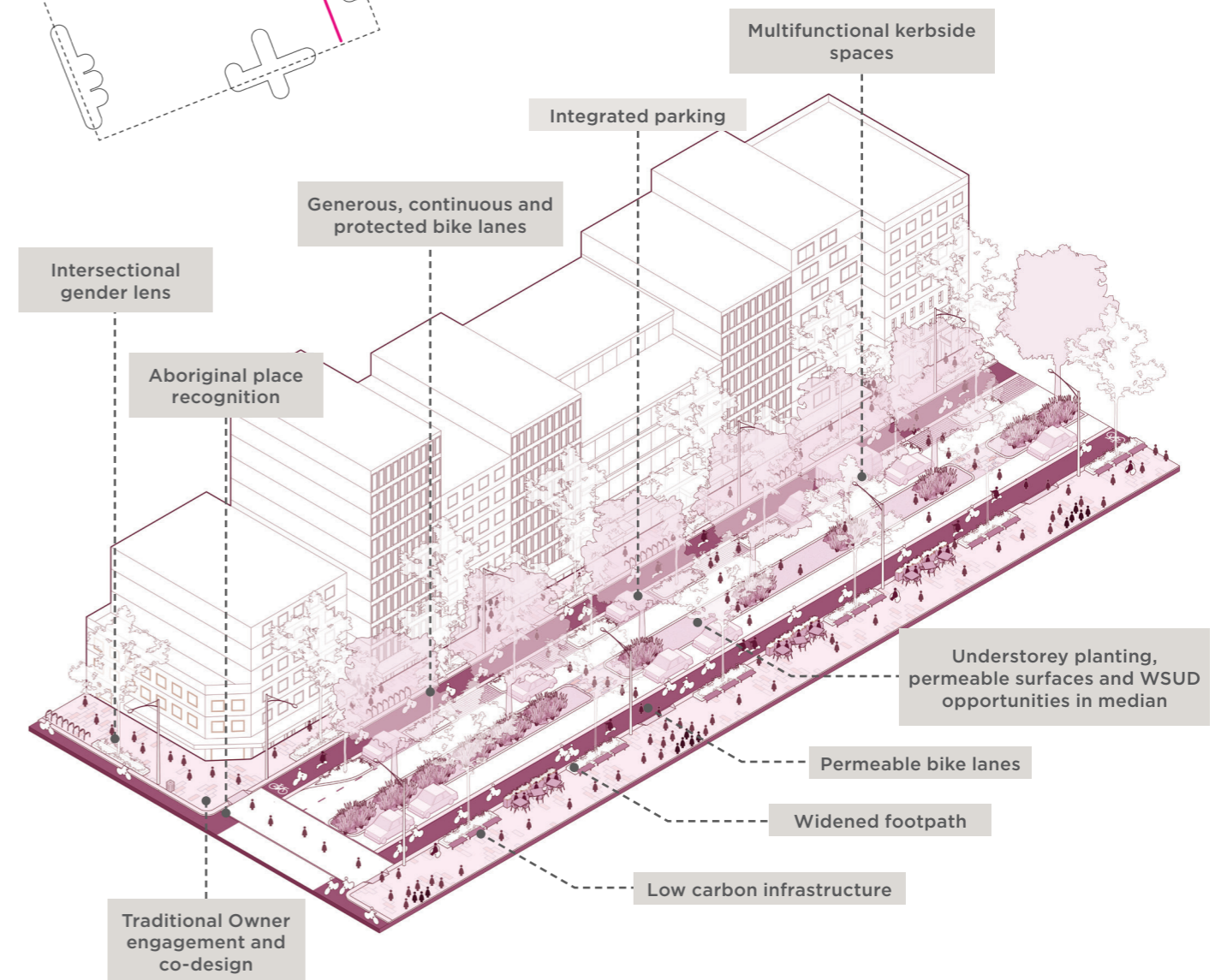

Figure 35: Safe mid-block crossing points

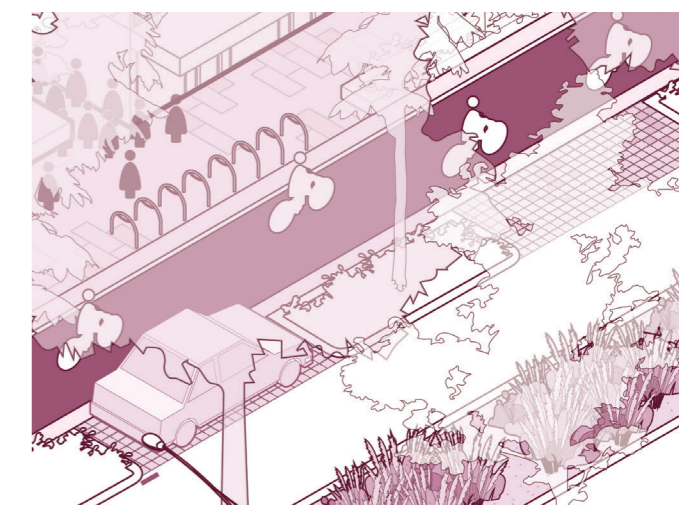

Figure 36: Permeable kerbside paving and parking spaces

STREET TYPE

LITTLE STREET

Little streets are high amenity pedestrian-centric environments. These streets facilitate the safe movement of people across and along the street, while ensuring local vehicle access for servicing, businesses and essential needs. Little streets support greening, open spaces, outdoor dining and activation.

Mode priorities

Existing and future modal priorities:

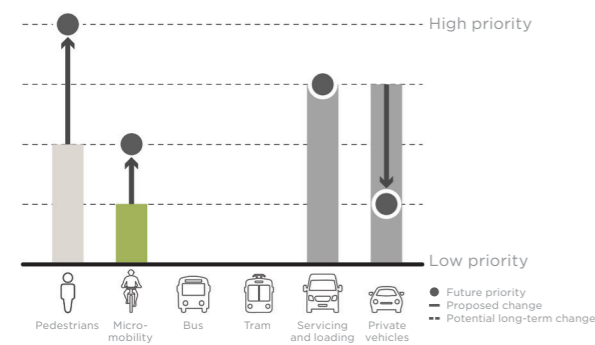

Mode allocation

Proposed typical section of a Little Street:

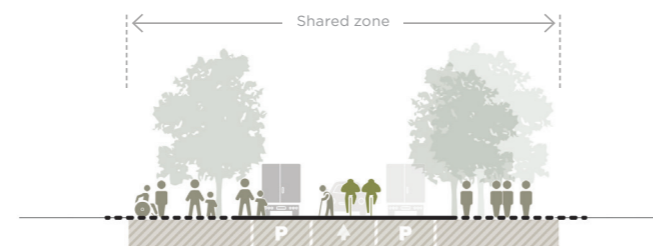

Design principles

Principles for this street type include:

MODE	KEY PRINCIPLES
Pedestrians	<ul style="list-style-type: none"> Prioritise ease of movement along and across the street including the use of continuous footpaths. Integrate raised thresholds at key intersections, destinations and crossing points. Establish shared zones in areas with high pedestrian volumes and remove delineation between modes through distinctive ground plane treatments and/or raised thresholds, suited to the conditions of the street. Create a slow movement environment through carriageway narrowing, chicanes and other traffic-calming measures suited to the context. Maintain appropriate footpath widths to cater for both movement and place needs, including accommodation for outdoor dining. Integrate traffic calming measures suited to the context including a combination of physical interventions and visual cues that avoid visual clutter and signage.
Micromobility	<ul style="list-style-type: none"> Support two way micromobility movement on suitable one way streets through contraflow cycle lanes. Provide convenient bicycle parking aligned with key destinations without impeding pedestrian movement zones. Designate strategic locations for e-scooters away from footpaths to balance user convenience and pedestrian movement.
Servicing and loading	<ul style="list-style-type: none"> Maintain access for emergency vehicles. Provide on-street loading and DDA parking to meet the needs of the street. In streets with high pedestrian demand, provide intermittent access for loading, waste collection and maintenance vehicles to minimise conflict with pedestrian in peak periods.
Private vehicles	<ul style="list-style-type: none"> Reduce through-traffic and support safe, efficient transport modes through vehicle filters at signalised intersections where appropriate. Implement intermittent or where possible permanent vehicle closures for to support pedestrianisation, activations and events suited to the context, while supporting traders to manage loading and servicing needs. Consider flexible / hybrid parking aligned with footpaths in strategic locations.

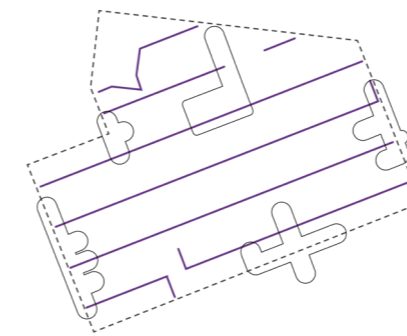

Applies to sections of:
 Flinders Lane, Little Collins Street, Little Bourke Street, Little Lonsdale Street, Spring Street, Therry Street, A'Beckett Street, William Street, Market Street, Franklin Street, Queen Street

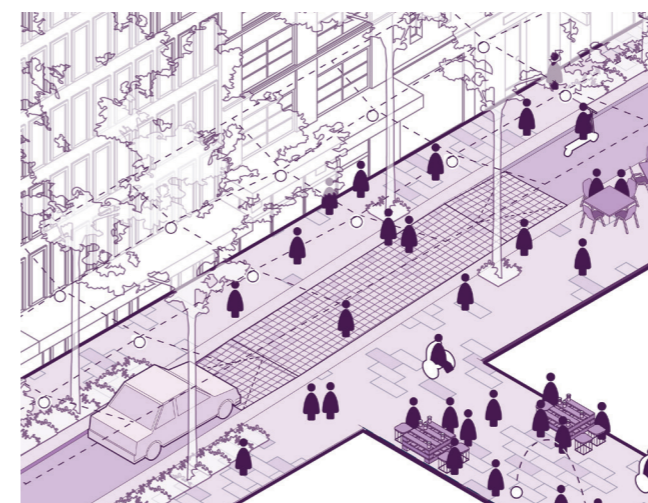
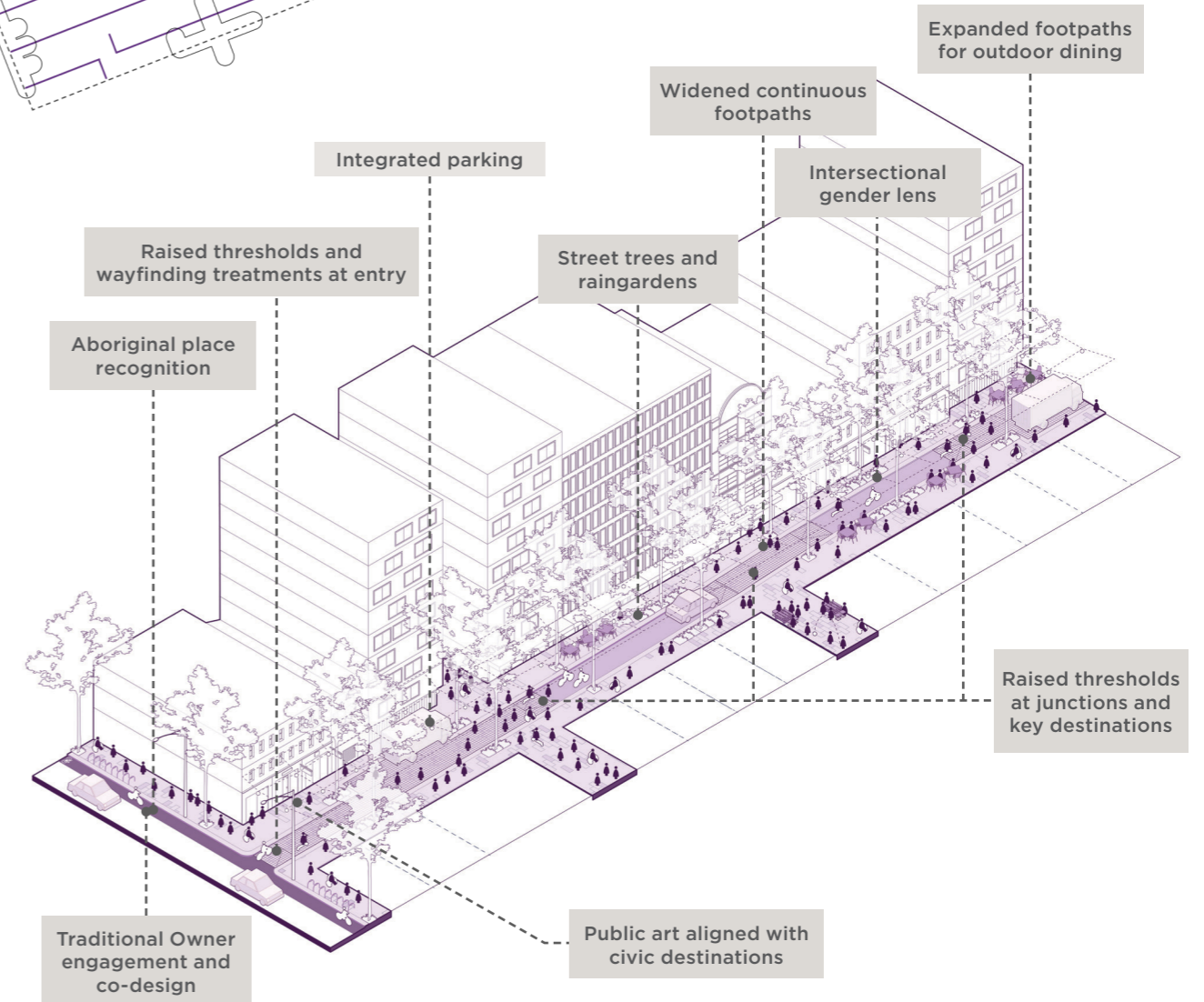

Figure 37: Traffic calming measures

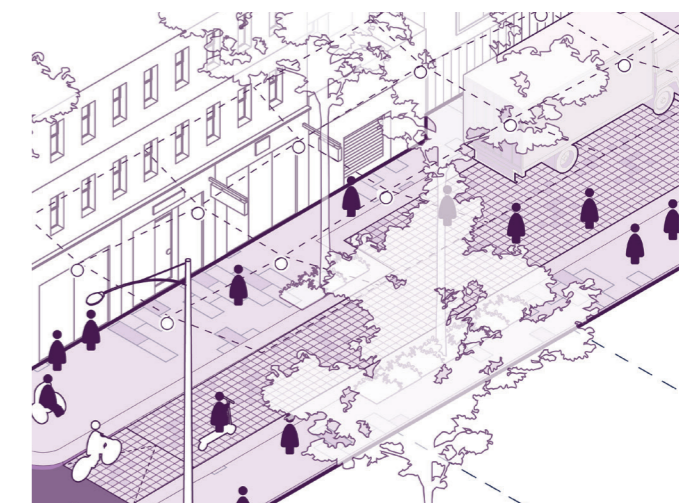

Figure 38: Differentiated street entry to announce a pedestrian-centric environment

STREET TYPE LANEWAY

Laneways are iconic, unique and functional environments in the Hoddle Grid, leveraging their predominately north-south orientation and ideal access to sunlight. They provide a mix of lively and quiet places that support businesses, facilitate efficient servicing and essential vehicle access, contribute to urban greening and encourage creative expression.

Mode priorities

Existing and future modal priorities:

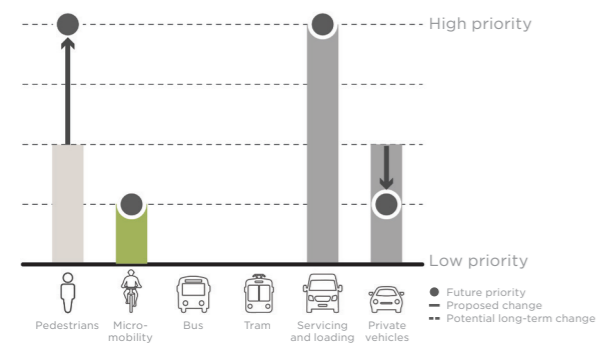

Mode allocation

A typical sections of a laneways:

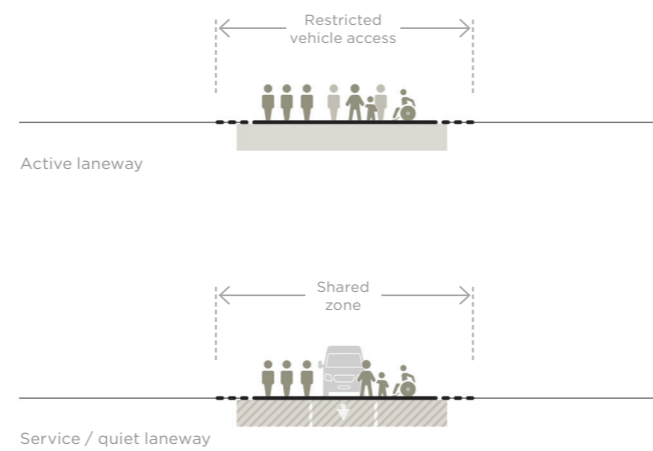

Design principles

Principles for this street type include:

MODE	KEY PRINCIPLES
Pedestrians	<ul style="list-style-type: none"> • Prioritise ease of movement along and across the street. • Remove delineation between modes, through ground plane treatments, to support a slow and shared environment. • Provide flexible spaces to support changing uses and moveable furniture.
Micromobility	<ul style="list-style-type: none"> • Support slow micromobility movement to access destinations. • Provide convenient bicycle and e-scooter parking where pedestrian movement and activation can be unimpeded. • Support two way micromobility movement on one way streets.
Servicing and loading	<ul style="list-style-type: none"> • Maintain access for emergency vehicles. • Provide timed access that allows for necessary service and loading / unloading access, while also supporting activation and pedestrian movement. • Provide flexible spaces for loading and servicing vehicles at convenient locations (i.e. near consolidated waste facilities).
Private vehicles	<ul style="list-style-type: none"> • Consider intermittent closures through use of traffic filters such as bollards. • Restrict strategic through movements and allow local traffic only (i.e. access to basement car parks).

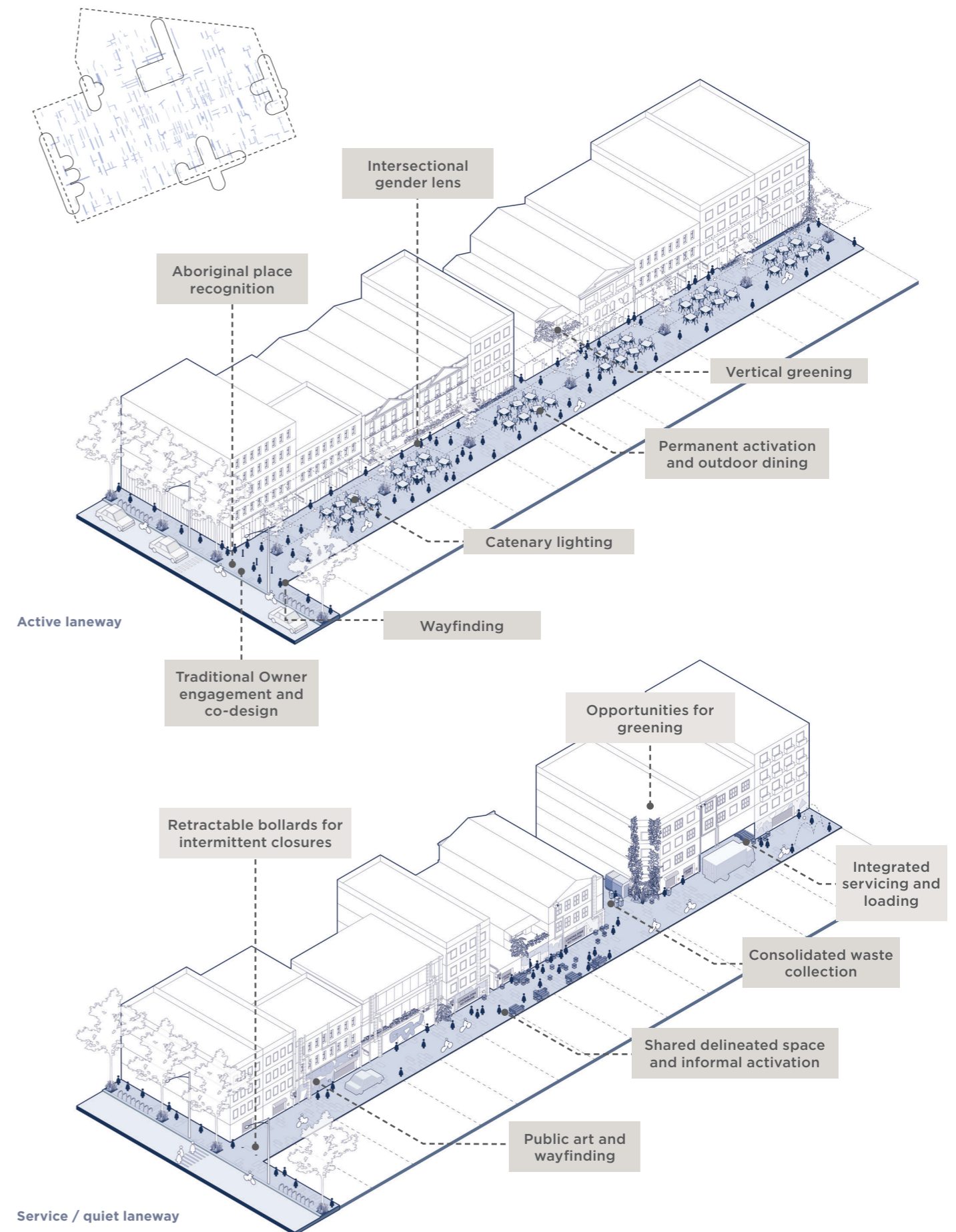

PART 2

PLACE CHARACTER

PLACE CHARACTER OVERVIEW

The Hoddle Grid is made up of distinctive business districts, retail and heritage precincts, and neighbourhoods. The design of streets should have regard to the valued qualities, functions and attributes of these places to enhance a sense of identity and build on the layers of history. Place character is a key contributor to the ability of a place to attract visitors. The combination of place characters that can be accessed and experienced is what differentiates and distinguishes Melbourne from other cities.

Figure 39: City places

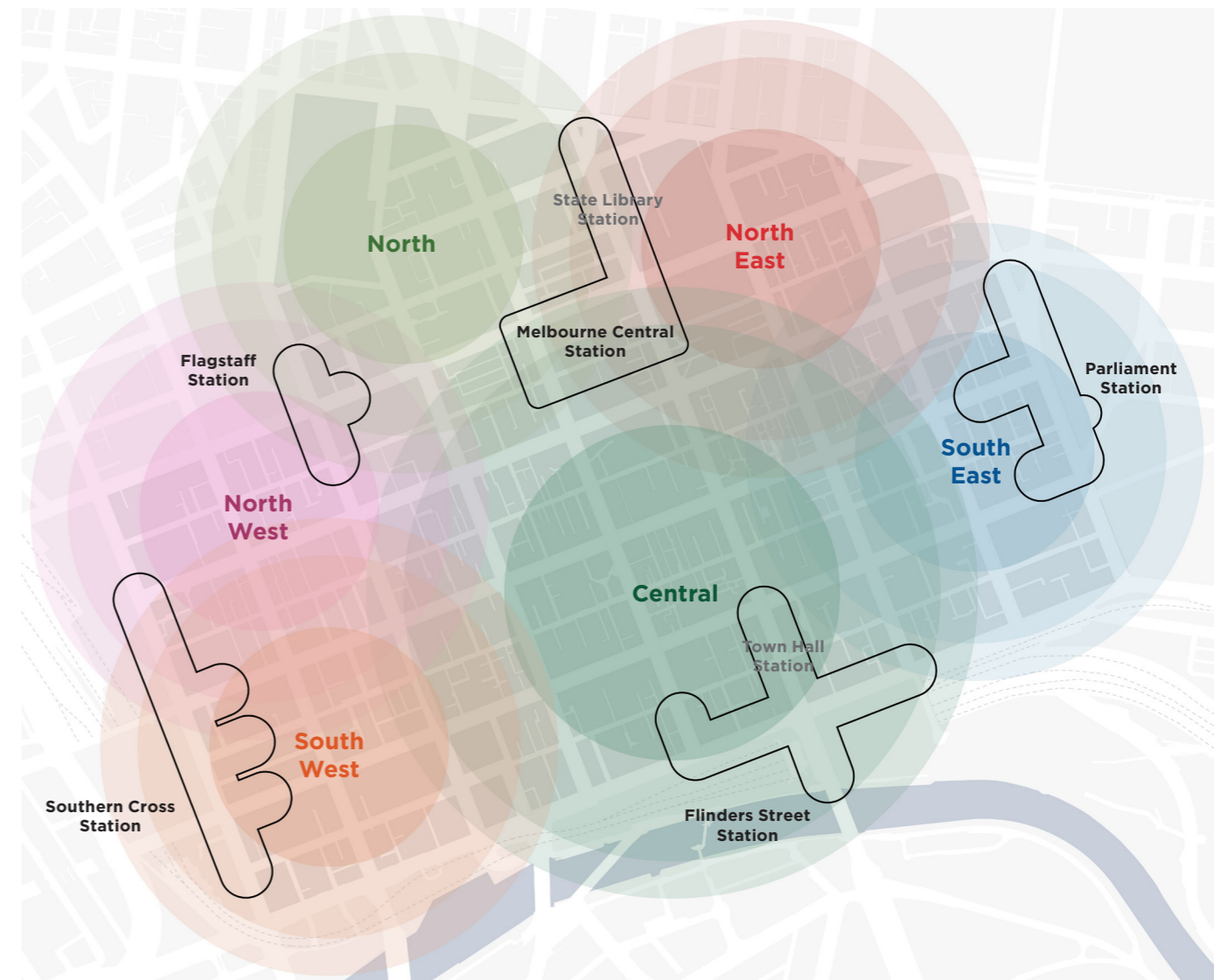

Key
□ Station hub

PLACE CHARACTER CENTRAL

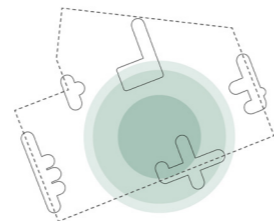

Street character

This city place must continue to be the heart of the city by supporting a confluence of activities. It must be a welcoming and inclusive place, furthering its core function as the historic gateway to the city from the south.

Streets in this city place must support the city's major retail core and legacy of promenading and arcaded shopping. Streets must also further their social and cultural function by providing opportunities for expression, creativity, parades and performance. Further to this, an ongoing sense of discovery must characterise a range of street experiences - from the civic spine that is Swanston Street to the many eclectic laneways.

Key destinations and land uses

Clusters of similar and complementary land uses include:

- Retail, malls and arcades
- Town Hall, City Square and Federation Square
- Existing and emerging train stations (Flinders Street Station, Melbourne Central Station, and Melbourne Metro State Library and Town Hall Stations)
- Temporary activation: demonstrations, parades, events
- Restaurants, bars and outdoor dining
- Street trading including kiosks and busking
- Yarra River - Birrarung (to south)

Strategic precincts

- Flinders Gate heritage precinct
- Flinders Lane heritage precinct
- The Block heritage precinct
- Post Office heritage precinct
- Swanston Street South and North heritage precincts
- Drewery Lane heritage precinct
- Elizabeth Street West heritage precinct
- Guildford and Hardware Laneways heritage precincts



Image 40: The civic spine (Swanston Street)



Image 41: Iconic and eccentric laneways (Degraes Street)

Figure 42: An example of a Melbourne Square in the Central region



Future Streets opportunities

1. Establish high amenity gateways to the Hoddle Grid

Prepare streets for increased pedestrian demand due to Melbourne Metro Tunnel Project. Streets surrounding existing and new stations will support wider footpaths, integrated tram stops, spaces to gather and meet as well as wayfinding and public art. Key streets include Swanston, Collins and Flinders Streets.

2. Deliver pedestrian priority on little streets to support activation of the retail core

Upgrade little streets as slow shared streets that prioritise space for pedestrians, places to dwell, outdoor activation and greening. Key streets include Flinders Lane, Little Collins, Little Bourke and Little Lonsdale.

3. Enhance street amenity to support activation of the retail core

Reinforce the retail core on Elizabeth and Swanston Street by providing sufficient space for pedestrian movement and dwelling. This includes increased space for activation, street furniture, public art and greening.

4. Regenerate Elizabeth Street as an ecological spine

In collaboration with Traditional Owners, enhance the cultural and historical recognition of Elizabeth Street as a significant creek corridor through creative and integrated water management, while supporting its role as an important public transit and pedestrian corridor through the Hoddle Grid.

5. Build on the iconic laneways

Continue to support north-south movement through urban blocks by creating people-centric little streets and laneways, and integrating wayfinding to highlight the connections.

PLACE CHARACTER SOUTH EAST

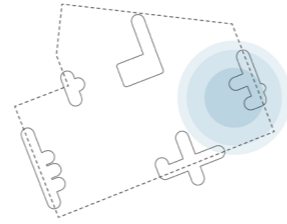

Street character

This city place must be recognised for its distinct character of thriving cultural precincts and historically significant buildings. A mix of grand destinations and intimately scaled streetscapes must continue to provide a variety of experiences to attract locals and visitors alike.

Streets in this city place must complement a diverse offering - from safely supporting the bustling movements of shoppers and workers during the day to facilitating the animated wanderings of diners and theatre-goers at night. Comfortable and pleasant journeys to both key destinations and hidden venues, at all times, must support this thriving hub of entertainment and culture.

Key destinations and land uses

Clusters of similar and complementary land uses include:

- Cultural precincts (Chinatown, Greek precinct)
- State significant theatres
- Hotels and retail
- Restaurants, bars and outdoor dining
- Parliament Station
- Parliament House, Treasury Gardens and Fitzroy Gardens (to east)
- Yarra River - Birrarung (to south)

Strategic precincts

- Collins East heritage precinct
- Bourke Hill heritage precinct
- Flinders Lane heritage precinct
- Flinders Lane East heritage precinct
- Little Bourke Street heritage precinct
- Flinders Gate heritage precinct
- Swanston Street South heritage precinct



Image 43: Distinct precincts that are activated day and night (Little Bourke Street)



Image 44: High quality spaces for meeting and gathering (Princess Theatre Forecourt)

Figure 45: An example of a little street in the South East region



Future Streets opportunities

1. Establish a village atmosphere surrounding major destinations

Expand footpaths, open spaces and forecourts to support pedestrian spill-outs, crowds and meeting points surrounding key civic, cultural and tourism destinations. This may include conversion of road spaces and/or extending existing forecourts. Key streets include Spring Street, Bourke Street, Little Bourke Street, Collins Street and Little Collins Street.

2. Create lively destinations on little streets

Support regular and intermittent closures of little streets to support different day and night activities, to balance outdoor dining and to facilitate special events and festivals, particularly supporting the cultural precincts.

3. Create safe and comfortable east-west bike connections

Enhance east-west bike paths along Bourke and Collins Streets to increase active travel options between the retail core and the east of the Hoddle Grid.

4. Enhance wayfinding through popular laneways

Reinforce pedestrian priority and wayfinding at key junctions with little streets and laneways through raised thresholds, space to dwell and improved greening. Key laneways include Meyers Place, Crossley Street, Liverpool Street, Market Lane, Corrs Lane and Rideway Place.

5. Embrace water in creative and sustainable ways

Deliver innovative Water Sensitive Urban Design (WSUD) interventions that support high amenity pedestrian environments which are susceptible to flash flooding and inundation, such as Little Lonsdale and Little Bourke Streets.

6. Improve visual and physical connections to the surrounding parks

Increase greening in streets and deliver new pedestrian crossings to blur the edges between the Hoddle Grid and surrounding Parliament and Treasury Gardens.

PLACE CHARACTER NORTH

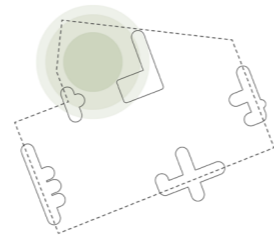

Street character

This city place must be a hub for social and daily life. It must build on its vibrant offering through utilitarian sheds and elaborate brick buildings characteristic of Victorian era markets.

Importantly, the streets in this city place must continue to support the Queen Victoria Market as a community anchor. Streets must showcase the colourful collection of produce and products, and must provide abounding opportunity for fleeting and meaningful interactions. This will be further supported by existing and emerging uses including Market Square, Munro Library and Community and Hub, and health care facilities.

Key destinations and land uses

Clusters of similar and complementary land uses include:

- Queen Victoria Market
- Existing and emerging community-centred open spaces, such as Market Square
- Restaurants, bars and outdoor dining
- Medical / health services (to north)
- Flagstaff Gardens (to west)

Strategic precincts

- Queen Victoria Market heritage precinct
- Elizabeth Street heritage precinct
- Melbourne Innovation District

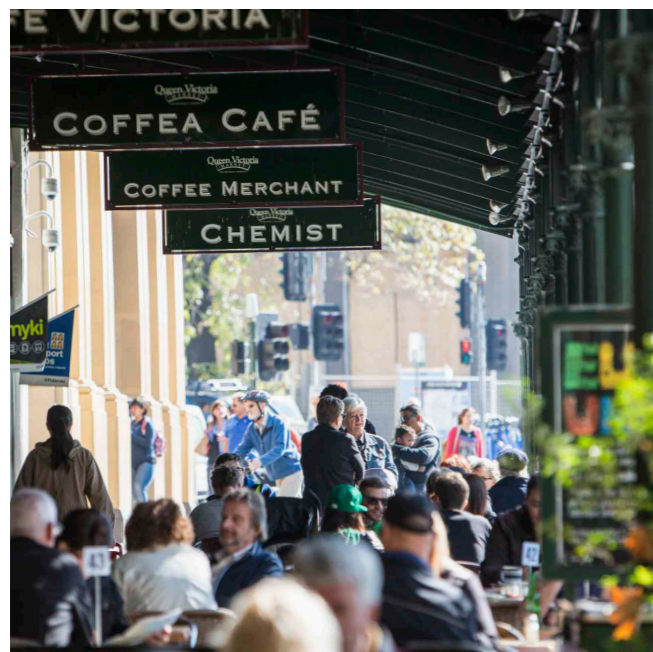

Image 46: Bustling and vibrant activity (Queen Victoria Market)



Image 47: Playful and intimate spaces (Queen Victoria Market)

Figure 48: An example of a City Street with bikes in the North region



Future Streets opportunities

1. Enhance sense of arrival to Queen Victoria Market

Establish new open spaces comprising enhanced greening, places to gather and activations surrounding Queen Victoria Market tram stops at Elizabeth and Peel Streets.

2. Improve active transport connections between RMIT and Queen Victoria Market

Deliver high amenity pedestrian and cycle corridor on Franklin Street supporting protected cycle lanes, new open space, greening and safe pedestrian crossings. Reduce crossing distances and maximise opportunities for mid-block crossings points.

3. Support the Melbourne Innovation District

Respond to the aspirations of the Melbourne Innovation District through creation of streets and spaces that support experimentation, rapid prototyping, showcasing and exchanging ideas, exhibitions and events. Explore opportunities for integration of emerging technologies. Key streets include Victoria, Franklin, Queen and A'Beckett Streets.

4. Embrace water in creative and sustainable ways

Deliver creative and innovative WSUD interventions that support high amenity pedestrian environments in streets which are susceptible to flash flooding and inundation. Key streets include Elizabeth, Therry, Franklin and A'Beckett Streets.

5. Enhance connectivity between the gardens and market

Improve visual and physical connections between Flagstaff Gardens with Queen Victoria Market and the future Market Square open space by creating a high-amenity pedestrian centric environment at William Street. Street upgrades are to maximise pedestrian crossings and enhance opportunities for complementary greening and recognise the cultural significance of the place.

PLACE CHARACTER NORTH EAST

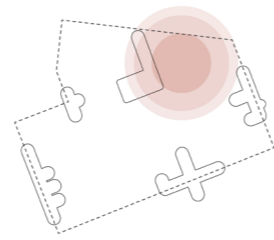

Street character

This city place must be an attractive and prosperous environment for collaboration and innovation. A complementary mix of uses including libraries, universities, student accommodation and recreational centres must collectively support the city's knowledge ecosystem.

Streets in this city place must contribute to a thriving environment for living, working and retaining talent. Streets must support students, researchers and teachers through high-quality spaces for stimulation and respite. They must provide a walkable network to further drive knowledge-based and creative pursuits, and provide experimental public spaces to encourage new ideas and community cohesion.

Key destinations and land uses

Clusters of similar and complementary land uses include:

- State Library Victoria
- RMIT University
- QV Melbourne
- Student accommodation
- Restaurants, bars and outdoor dining
- City Baths and other recreational facilities
- Melbourne Metro State Library Station

Strategic precincts

- Little Lonsdale Street heritage precinct
- Melbourne Innovation District

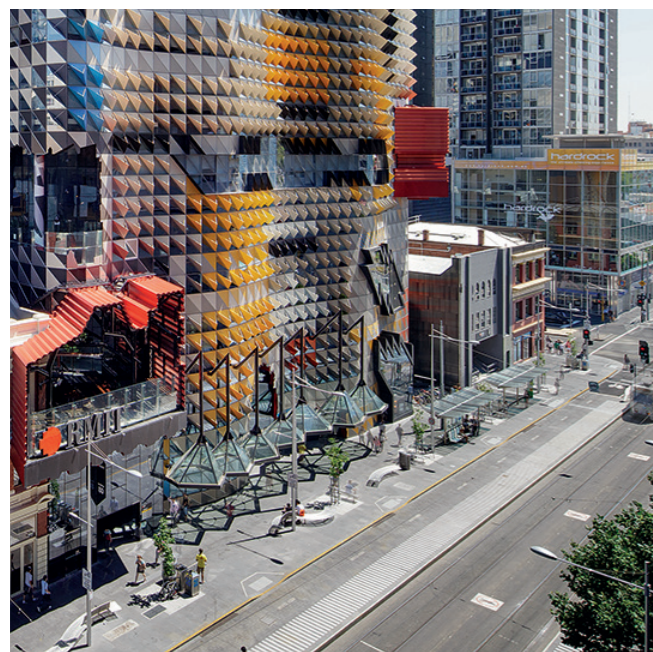

Image 49: Distinct educational buildings and street interfaces (Swanston Street)



Image 50: Urban squares for both formal and informal activities (A'Beckett Street)

Figure 51: An example of a City Street with buses in the North East region



Future Streets opportunities

1. Establish new high-amenity gateways to the Hoddle Grid

Prepare streets for increased pedestrian demand, particularly around the emerging State Library station at La Trobe and Franklin Streets through generous footpath widths, places to gather, greening and activations.

2. Create streets which support the ambitions for the Melbourne Innovation District

Respond to the aspirations of the Melbourne Innovation District through creation of streets and spaces that support experimentation, rapid prototyping, showcasing and exchanging ideas, exhibitions and events. Explore opportunities for integration of emerging technologies, particularly at Russell and La Trobe Streets.

3. Complement surrounding civic and institutional functions by creating spaces for collaboration

Support a variety of open spaces including linear parks, forecourts, squares and pocket parks aligned with civic and institutional uses. New spaces should support greening, while showcase surrounding heritage buildings and destinations. Key streets include Franklin Street, Russell Street and A'Beckett Street.

4. Maximise pedestrian connectivity and interaction

Improve amenity of street junctions, reduce crossing distances and maximise opportunities for mid-block crossings points as well as improve the safety and amenity of tram stops. Key streets include Victoria, Swanston and La Trobe Streets.

5. Embrace water in creative and sustainable ways

Deliver creative and innovative WSUD interventions that support high amenity pedestrian environments in streets which are susceptible to flash flooding and inundation, such as Exhibition, Lonsdale and Franklin Streets.

PLACE CHARACTER SOUTH WEST

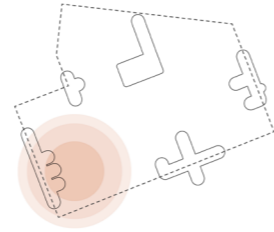

Street character

This city place must be a premier location for office and commercial activity. It must leverage its relatively contemporary architecture, small heritage precincts and links to the river to provide places to meaningfully connect and interact.

Emphasis in this city place must be on ground floor activation and outdoor dining, building on Melbourne's iconic coffee and dining culture. As a hive of activity and exchange, the streets in this city place must support attractive environments to conduct business, to connect across sectors, and to welcome regional and international guests.

Key destinations and land uses

Clusters of similar and complementary land uses include:

- Southern Cross Station (with regional and airport links)
- Offices and commercial uses
- Hotels
- Yarra River - Birrarung and Greenline Project (to south)
- Marvel Stadium (to west)

Strategic precincts

- Bank Place heritage precinct
- Bourke West heritage precinct



Image 52: High quality landscaped public realm (Market Street)



Image 53: Architectural variety and intimate street spaces (Bank Place)

Figure 54: An example of a little street in the South East region



Future Streets opportunities

1. Establish a gateway to the Hoddle Grid at Spencer Street

Widen footpaths to cater to high pedestrian volumes generated by Southern Cross Station and Marvel Stadium. Support streamlined interchange journeys, particularly to and from Southern Cross Station to Spencer, Bourke and Collins Street tram routes. Implement new open spaces aligned with transport interchanges and tram stop upgrades, particularly at Little Collins Street.

2. Improve active transport through the Hoddle Grid along Spencer Street

Deliver protected bike lanes on Spencer Street to improve cycle connectivity between West Melbourne and Southbank.

3. Create new spaces to complement commercial and office activity

Support commercial and office activities by providing diverse, green open spaces to rest, gather and collaborate. Key streets include Flinders Lane, Little Collins Street and Market Street south.

4. Enhance visual and physical connectivity between the Hoddle Grid and Yarra River - Birrarung

Improve pedestrian connectivity and amenity on Flinders Street to better interface with the Yarra River - Birrarung and Greenline Project.

5. Improve east-west bike movement

Improve east-west bike movement on Bourke and Collins Streets to increase active travel options and enhance connectivity between retail core, Hoddle Grid West and Docklands.

6. Embrace water in creative and sustainable ways

Integrate sustainable and creative water management measures at Flinders Street and adjoining streets which are susceptible to flooding, while enhancing recognition of their proximity to the Yarra River - Birrarung.

PLACE CHARACTER NORTH WEST

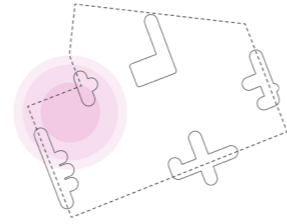

Street character

This city place must be a distinct hub of commercial, institutional and civil activity. Its relatively high elevation reinforces the prominent role of this place within the broader state-wide judicial system.

This city place will build on its architectural motifs of order and transparency, and celebrate the coming together of old and new. Emphasis in this city place must be to provide attractive ground floor environments with diverse spaces to meet, connect and rest.

Key destinations and land uses

Clusters of similar and complementary land uses include:

- Flagstaff Station
- Law courts
- Chambers and legal offices
- Institutional buildings and colleges
- Flagstaff Gardens (to north)
- Emerging West Melbourne (to north west)

Strategic precincts

- Bourke West heritage precinct

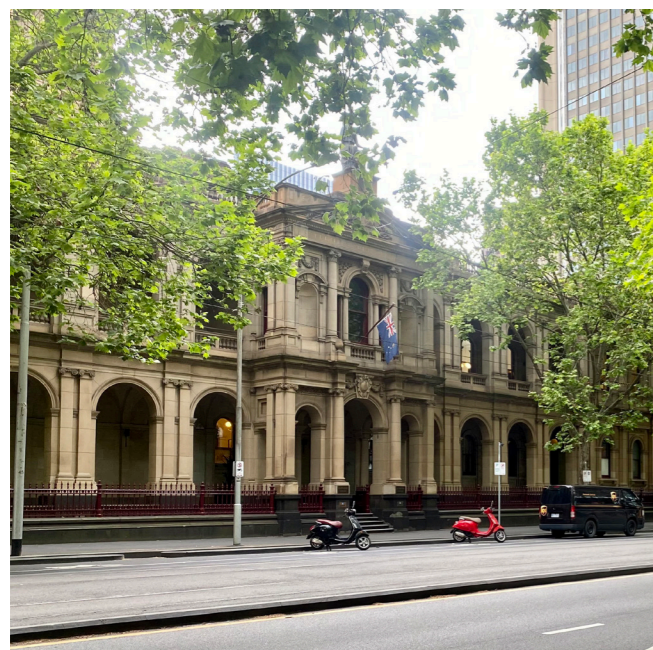

Image 55: Law court buildings and tree-lined streets (William Street)

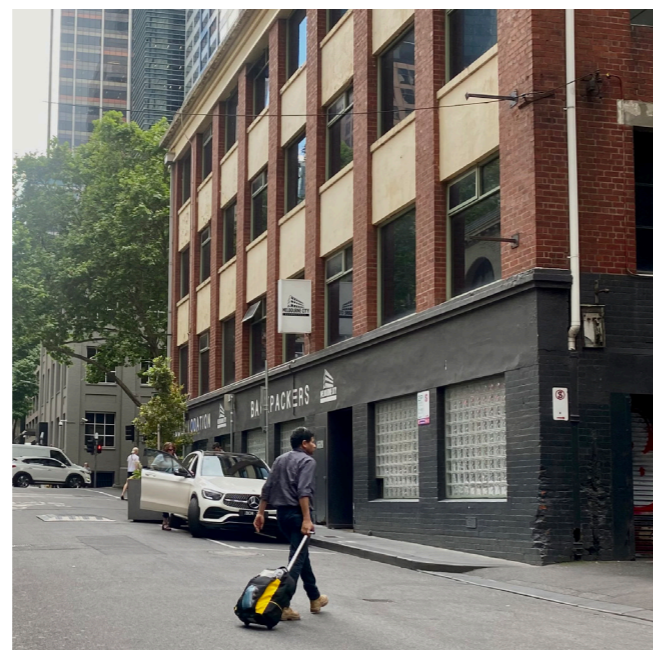

Image 56: Intimately scaled, slower settings (Bourke West precinct)

Figure 57: An example of a Melbourne Square in the North West region



Future Streets opportunities

1. Establish green spines through the Hoddle Grid

Enhance greening in the west of the Hoddle Grid through new vegetation, tree canopy and WSUD interventions, complemented by open spaces for people to seek respite. Key streets include those with central medians, such as Lonsdale and Queen Streets.

2. Enhance streets as places for people complement the Legal Precinct

Support legal and institutional activities by providing diverse, amenable and safe open spaces to meet and interact. Key streets include Little Lonsdale Street, Queen Street, and Little Bourke Street and surrounding laneways.

3. Improve public transport connectivity

Support streamlined interchange journeys to and from Flagstaff Station and enhance pedestrian movement along little streets to improve connections to the retail core. This also includes accessibility and amenity improvements to tram stops at La Trobe Street and William Street.

4. Enhance wayfinding through popular laneways

Reinforce pedestrian priority and wayfinding at key junctions with little streets and laneways through raised thresholds, space to dwell and improved greening. Key laneways include Langs Lane, Crombie Lane, Park Street and Merriman Lane.

5. Improve visual and physical connections between the surrounding parks and the Hoddle Grid

Increase greening in William and La Trobe Streets to blur the edges between the Hoddle Grid and surrounding Flagstaff Gardens. Maximise the topographic vantage points, particularly on La Trobe Street to frame views through the city and toward landscape features.



NEXT STEPS

The Future Streets Framework will assist City of Melbourne to identify upcoming streetscape and transport projects to be delivered through the Capital Works Program or other funding program.

There are many opportunities for street upgrade projects (funded publicly, privately and shared) in the Hoddle Grid. Priorities will be rationalised using this framework to ensure the investment in streets achieves a multitude of social, economic and environmental benefits. Determining priority projects will also provide clarity to City of Melbourne, stakeholders and the community on the type of change envisaged in streets aligned with the implementation of the Transport Strategy 2030.

The design principles of street types and the street character of places together communicate the ideal outcome for the function and design of streets. Where the design principles and place character outcomes are not met, based on the current condition of streets, projects will be identified for prioritisation.

Street upgrade priorities will be determined through a range of other relevant factors. This includes projects that:

- Respond to community consultation feedback and neighbourhood priorities for the central city.
- Support the movement objectives outlined the Integrated Network Plan in the Transport Strategy 2030.
- Complement planned major infrastructure or development projects.
- Have in-principle strategic support from Department of Transport and Planning and relevant service authorities.
- Provide new open space to support the amenity and function of existing destinations.
- Improve amenity in streets which have experienced significant new development and change in land use.
- Make permanent City Reactivation interventions where they have led to positive public realm outcomes.
- Address sub-optimal footpath widths, alleviate pedestrian congestion or improve poor quality pavement.
- Address flooding and/or drainage impacts in the Elizabeth Street catchment.

Further analysis and investigations of the 'Future Streets opportunities' identified in Part 2 of this framework will help refine priority projects and scale of intervention. The type of projects this framework could identify include:

- **Minor street upgrade:** small upgrades and interventions that build on the design principles of street types. These projects will be prioritized for design and delivery over a 5 year timeframe.
- **Major street upgrade:** Transformative projects re-envisaging the movement and place function of a street to respond to the design principles of the street type. These projects will be prioritized for design and delivery over a 10+ year timeframe.
- **Masterplan:** transformative streetscape projects that will undergo a master planning and implementation planning process with the opportunity to identify interim or smaller interventions over a 10+ year timeframe.
- **Operational projects:** Smaller projects which require ongoing funding to support the operation of uses within a street or laneway that could be delivered in a 2-3 year timeframe.

How to contact us

Online:

melbourne.vic.gov.au

In person:

Melbourne Town Hall - Administration Building
120 Swanston Street, Melbourne
Business hours, Monday to Friday
(Public holidays excluded)

Telephone:

03 9658 9658
Business hours, Monday to Friday
(Public holidays excluded)

Fax:

03 9654 4854

In writing:

City of Melbourne
GPO Box 1603
Melbourne VIC 3001
Australia



Interpreter services

We cater for people of all backgrounds
Please call 03 9280 0726

03 9280 0717 廣東話
03 9280 0719 Bahasa Indonesia
03 9280 0720 Italiano
03 9280 0721 普通話
03 9280 0722 Soomaali
03 9280 0723 Español
03 9280 0725 Việt Ngữ
03 9280 0726 عربي
03 9280 0726 한국어
03 9280 0726 हिंदी
03 9280 0726 All other languages

National Relay Service:

If you are deaf, hearing impaired or speech-impaired,
call us via the National Relay Service: Teletypewriter (TTY)
users phone 1300 555 727 then ask for 03 9658 9658
9am to 5pm, Monday to Friday (Public holidays excluded)

melbourne.vic.gov.au



CITY OF MELBOURNE